

# The Australian Thermaleer

Information, Competition Results and Articles for Australian SAM Chapters and Groups

Issue No.3

April - June, 2020



270

WESTERN AUSTRALIA



SAM 1993



SAM 84 Queensland



Oldtimer model with powerful modern engines. Must be following the trends set in Model Oldtimer flying?



ALICE SPRINGS  
Masters Games

10-17 October 2020

*The Friendly Games*

<https://www.alicespringmastersgames.com.au/>

**CANCELLED**



**SAM 600 Australia - Victorian Old Timers Association Inc. Committee**



President  
**Kevin Fryer**  
Home: 03 9842 4361  
Mobile: 0438 561 440  
Email: fryerkd@gmail.com

Vice President  
**Lyn Clifford**  
Home: 03 5456 2541  
Mobile: 0429 165 669  
Email: lynclifford@exemail.com.au



Secretary/Treasurer  
Public Officer  
**Brian Dowie**  
Home: 03 9706 2074  
Mobile: 0402 918 916  
Email: brianflyrc@hotmail.com



Contest Director  
**Don Grant**  
Home: 03 5623 4966  
Mobile: 0419 871 506  
Email: drgrant@dcsi.net.au



Committee Member  
**Pat Keeley**  
pekeely@live.com

Newsletter Co-Ordinator  
**Brian Laughton**  
brianlaughton1957@hotmail.com

Safety Officer  
**Steve Gullock**  
coodgiebear@hotmail.com

Member Registrar  
**Roger Mitchell**  
03 5456 4236

"The Thermaleer" is the official newsletter of SAM 600 of Australia, Victorian R/C Old Timers Association (SAM600) Inc.

**Contests..... Remember them? When will we have them again?**



Cohuna Nov 2017

1st Place winners of Texaco at Cohuna in November - L to R Steve Gullock, Lyn Clifford, Don Grant, Graeme Gulbin, Robert Taylor, Steve Jenkinson.

**From the SAM 600 President Kevin Fryer.**

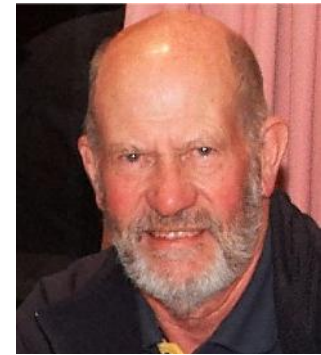

The Sam 600 increased height applications are progressing well. There are 70 pages of script that have to comply to CASA's requirements and the last meeting should finish this. Joe Finocchiaro will double check the wording and if OK he will send it on to CASA.

After reading the Brown JR Tune-Up article in the COASTAL FLYER newsletter I decided to get Norm Campbell's Brown Jr engine running. As the crank was very short, I machined up a sleeved nut to hold prop and spinner on.

I found it very tricky to get the point gap set to .008" using the eccentric bush - it took about 2 hrs. I set the timing to 28 degrees advance.

The needle valve had flats all over it so I made up a sleeve and re-machined it.

The fuel I decided to use was 15% Klotz, 5% Caster and 5% Nitro.

No starter was needed nor should one be used on these old engine. The Brown started on about the second flick and ran to about 5500 RPM.

The engine's running temperature started to rise very quickly, and it detonated and spat the prop off before I could retard it.

I then turned up a double-finned heat sink to be held on by the spark plug. This lowered the running temp by about 450 degrees. The Brown now runs out a full tank no problems.

I now have to finish off my Red Zephyr model to put it in.

When we get our increased height limits it will not be necessary to alter any fuel allotments or engine run times.

It is going to be interesting to see all the new models you have built over the break.



Keep Safe,  
Kevin Fryer.

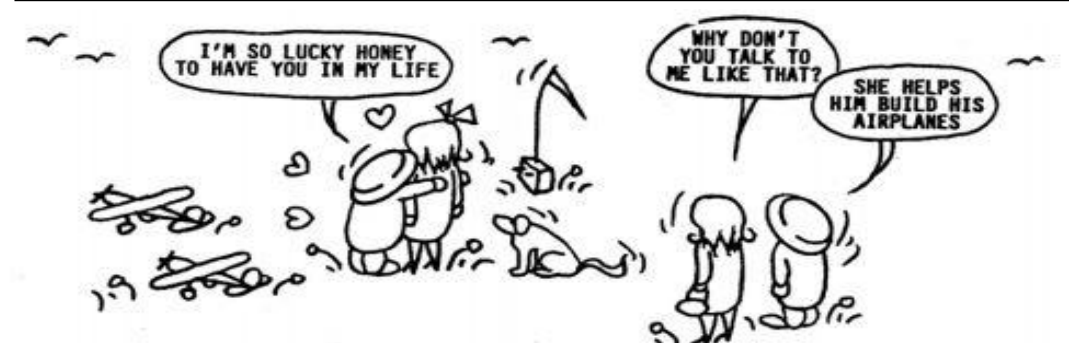

## Sam 600 Contest Director's Report. From Don Grant.

Due to the fact that we have not had any Competitions I am just passing on what I have been doing lately.

Some months ago Kevin, Brian Dowie and Brian Laughton and myself inspected the Bacchus Marsh field with Joe Finocchiaro. It is in the early stages of development with only a North/South strip and a small artificial lake/dam parallel to, and dangerously close to the strip.

Looks to me like they dug it out to level the strip. Cost them tens of thousands to do it. Obviously they don't have any practical farmers in the club otherwise it would have been done for a fraction of the cost.

Until they get an East/West strip in it will be a pig of a place to fly if the wind is coming from the West or East as the club rules state that you can't fly on the Western side of the strip. Taking off to the west and landing with an easterly wind will be difficult.

Despite Brian Dowie having been there before he got lost so Joe and I had to cool our heels and temper for more than hour until the other three arrived. I had the greatest distance to travel and got there first.

I have built an electric 1/2A Bomber with a wing which came from Norm Campbell. I had hoped to use the wing as I received it as it looked OK but I discovered that

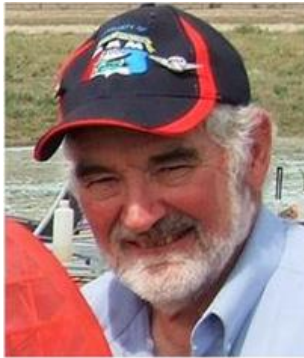

one of the small top spars was broken between most of the ribs. Once the covering was off it didn't look so good so I had to do a substantial rebuild. The fuz I built for it came out tail heavy, so I had to put 2oz. of lead in the nose. Flies well though, fiddling with incidence to try and reduce the lead.

I bought a Gas Champ from a deceased club member's estate. It wasn't built by the deceased and it has a P&DARCS sticker on it. Maybe ex Tony Cincotta? The wing is beautifully built and is being recovered. When finished I will start on the Fuz. The original silk and dope covering had gone brittle and I got sick of patching it.

I have set the Gas Champ up with an electric motor and receiver/stabiliser/vario to be used as a height ceiling demonstrator if we have to use one because of the new CASA regulations. I have done some trials with the 1/2A Bomber and found that once past 400m. /1300ft. it is getting hard to see.

The photo opposite is of an unknown pylon model from Norm Campbell. Can anybody tell me what it is? The wingspan is 79" tip to tip and is slightly under cambered with a 13" Cord.

If anybody knows its name could you please contact me at [drgrant4475@gmail.com](mailto:drgrant4475@gmail.com) or 0419 871 506.

### From Brian Laughton

Good news, I have finished my aerial-tow 1/4 scale Woodstock glider. I haven't flown it yet. The colour scheme is from a full size Woodstock housed at the Bendigo glider club.





### The Flying Pencil by Alan King.

From Brian Laughton.

Email to Bob Angel, Editor,  
SAM 26 USA Newsletter Editor.

Just a few words about the model you had on the front page of your newsletter #349. You were nearly right, it is called "The Flying Pencil" and was designed about 12,000 miles away from Europe in Melbourne, Australia, by who we considered at the time was the best designer, builder and flyer in Australia, Alan King!

The model was designed to fly in our freeflight class, "Power Ratio" competition.

This class was a bit different to other competitions in that it gave you a minimum engine run of 5 seconds and a maximum flight time of 180 seconds. So if you were lucky enough to get both of these in the same flight you would get a 36 total for the flight, the best score you could get.

We never had fly offs in this comp because it was very hard to get exactly a 5 seconds motor run. Therefore the model designed for this event had to climb well, transition well and glide well, and all of Alan's models did this.

The model itself was designed in the late 1940's and the plan was printed in the 1950 Aeromodeller Annual which my mother gave me for my 15<sup>th</sup> birthday and I have treasured it ever since.

Size-wise this model has a very similar wing to the Playboy Senior but has a longer moment arm and about a 40% tailplane. It was powered originally by an ETA 29 English glo motor.

His next design after this was called a "Pencil Bomber". It was similar in size but it had a more streamlined fin and pylon shape, single leg undercarriage and a cowled motor with a spinner. Power was a Dooling 29 swinging a single blade prop. This model was very spectacular to watch fly. Unfortunately I have tried for years to get a plan for this model as I would like to build one but have not been successful.

As you can judge by the photos I have built a "Flying Pencil" for Australia's Old Timer Nostalgia events. Mine is powered by a K&B 40 and flies very well, placing in many comps Down Under.

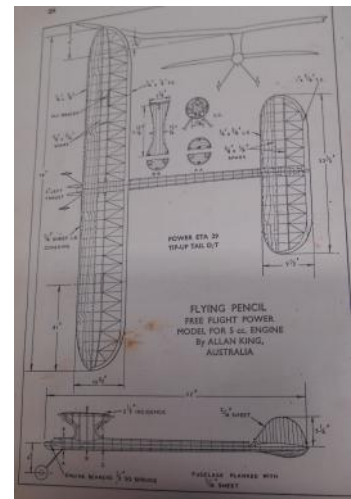
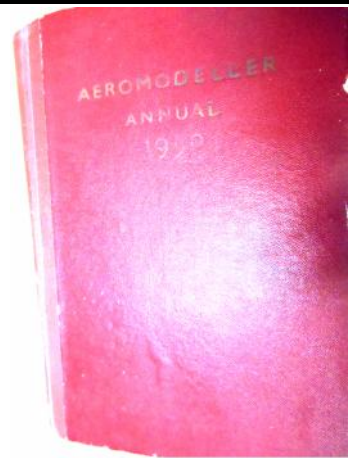

## SAM 1993 SOUTH AUSTRALIA (Formed 1993)

COMMITTEE

President: Rex Brown 0468 448 375

Secretary: Peter Leaney 8337 2836 pleaney@bigpond.net.au

Meetings held at the home of Rex Brown from time to time



### HERITAGE STORY DON HOWIE 1937-2020.



Don was born in 1937, so most of his young days were during World War II, when returning pilots from the war made visits to his home. Modelling in South Australia got going with people like Gordon Burford making model engines and Bill Evans cutting balsa and producing model kits, from about 1948. Don's first introduction to model flying with I.C. engines came when control-line flying started in 1949 at Colley Reserve in Glenelg on one Sunday each month.

Don soon found that power flying was the most interesting and free-flight was flown at West Beach, before the present Adelaide airport was built. He rode down to West Beach on Sundays on his bicycle and saw some great models flying by people like Bill Evans, Mal Sharpe, Kevin Greene, Rob Thompson and others.

Don's first engine was a Frog 100 diesel and Vandiver model (Frog) control-line kit, bought by his father as a present in 1949. This was flown on a private estate near his home. In 1950 it became a popular flying site on Saturday afternoons for control-line models, and his own-design stunt models with Elfin 1.8cc diesel power flew well. Late 1950, models with the new FROG 500 red glo turning 9x6 props were too noisy for the neighbours, so the flying site was lost.

Next Don turned to Jetex power using the Jetex 100, then later the Jetex 50, which was cheaper to operate. These were flown on ovals and large paddocks,

near his home. The models were all lost in thermals, so that ended Jetex flying.

Next Don turned to free flight, flying at Rakes Road, Hampstead, with the Prospect Club, on the last Sunday of the month, quite a long trip on his bicycle, but often he was driven there by his father. Don's first model was a "Mercury Mallard", with his great Elfin 1.8cc diesel, and he lost it first day out in a thermal.

Don met many great modellers at Rakes Road flying field, who became good friends until they passed away. Max Starick and Allan (Bluey) Coppock were fantastic builders and the "Rudderbug" R/C model is shown in the photo, built by Max in 1952. Don also knew Rob Thompson as they flew C/L together in 1950, and remembers riding down to West Beach one time with Rob holding a Hyphen 500 F/F model powered with a Sabre 250 diesel, made by Gordon Burford in 1951.

Don then decided to design his own F/F models, up to 4 feet span. The best engine in 1952 was a Mills P.75cc diesel that was super easy to start. Don then flew in events run by Bill Evan's Model Flying Club, sponsored by the Chrysler Motor Co. in Adelaide. He remembers winning a power scramble event in 1953, winning a voucher to spend at Bill's Hobby Centre in Franklin Street, Adelaide.

In 1954, Don recalls entering the Malala Nationals, run by South Australian Associated Aeromodellers, paying his money to Bill Grabowski. The Nationals was at an old Airforce Base and the sleeping conditions were terrible. He left early, not flying in any events. Don never received his MAAA number, which should have been in the low hundreds.

Radio control, however, was Don's new interest. There was Barry Catford, who was a friend of Garry Cooper (the Elfin Car maker) who were both Aero-modellers, though now interested in Sports Cars. Barry made a single-channel radio set in 1953, that

worked on the bench, but they never got to fit it into a radio model such as a Rudderbug.

Don often went to see the radio models fly in the nineteen-fifties, but the tuning, multiple size and voltage of three sets of dry cell batteries, just to get the rudder tab to move, seemed hardly worth the effort.

Don followed the trends in magazines, and in the early nineteen-sixties, the Germans had simple, reliable radio control systems using tone filters.

Don's first radio set in 1962 was a Metz Baby that used a servo instead of a rubber-band driven escapement. This set used two dry "D" cells in the transmitter and four pencells in the model to work the receiver and servo. Don designed a four foot span model using a Taipan 1.5cc diesel and flew it with the boys at the Constellation Model Club sites. He remembers flying many times with Doug Saxby who had obtained the new Kraft single channel receiver that worked with two pencells - only 3 volts.

Rob Thompson, who had started Southern Models in 1956 with Rex Myers (Aero Flyte) was flying a 5 foot span model with an OS radio and an OS 19 glo R/C engine, that had two-speed engine control. This model became the first Aero Flyte "Hustler" kit, a great beginners model in the nineteen-sixties.





About this time Don read stories about proportional radio, thinking it would be better than reeds (tone filters). It was in early 1967 when he visited the 20th MAAA Nats at Strathalbyn for the radio control events. The most impressive flyer was Tom Prosser from Parkes, NSW, who was now using the yellow Kraft proportional equipment.

Phil Kraft won the World R/C Championships in 1967 at Corsica and early in 1968 introduced his Kraft Gold Medal series of R/C radios, the best and most reliable sets in the world.

In 1968, Brian Horrocks and others were building the Heathkit, designed by Kraft. Leo O'Reilly visited Kraft in Los Angeles, USA, and obtained the lower cost P>C 5 proportional that Don decided to purchase on his next trip to the USA.

Constellation Club obtained Woodstock flying field (10 acres) which was now being purchased from 1969 and Don now joined this club. He had bought a Taipan 61 R/C glo engine in 1968 and built two models, a Senior Falson (Goldberg models) and a VK Cherokee (VK Models) in that year.

In 1970, Don became Secretary/Treasurer of Constellation M.F.C. when Graham Ward retired from this position. Doug Saxby (President) had known him for many years so he recommended Don for this position in the Club.

Late 1970, Don noticed that the State Newsletter each month only contained control-line and free-flight reports, but no information about the new craze, proportional r/c multi flying, with many new members joining Constellation M.F.C. Don then started writing radio reports each month in this Newsletter.

Don managed to pay-off the loan for Woodstock flying field in three years - the club had many public displays. He remembers going to Kangaroo Island and Port Lincoln in a DC3 with their models to give flying displays on their ovals. About 1978, the club decided to buy a larger field of 20 acres, found by Jim Lynch, at Brooks Road and Don obtained the loan from the State Bank for this new field which he also managed to pay-off again in three years.

In the nineteen-eighties Constellation Club amalgamated with N.E.D.A.C. Club and bought a further 20 acres of land, east of the present field.

Late in 1977, Don met Merv Buckmaster and John Rogers at the home of Max Starick. Max started a column in their Airborne magazine, first called "For Old Timer Sake" and Don's first column in Airborne magazine, "South Australian R/C State Championships", appeared in Airborne magazine number 23, January 1978. Another writer, Brian Winch, also started about this time.



Don eventually wrote the Old Timer column in Airborne "For Old Timers Sake" until the magazine folded, like most modelling magazines.

After the 1999 "Golden Era" air races at the Constellation Club, David Boddington asked Leo O'Reilly to get Don to write a report for the AMI magazine in the U.K. on the air races event.

This was the start of Don's writing in the English magazines. Don asked Tony Dowdeswell (owner of AMI magazine) if he could write a Vintage column in the magazine and the first column was April, 2000, which Tony titled "For Old Times' Sake". Don wrote a column each month and visited the U.K. most years, along with the SAM Champs in the USA.

The AMI magazine died a few years ago and the articles which were included in the "Aero Modeller" centre section of the AMI magazine, now became the new Aero Modeller magazine. This magazine is still published in the U.K. each month and Don continued to write his articles, with the help of Maris Dislers (the engine writer) and the articles appeared about every two months.

Don became unwell around the end of 2019 and after a short illness passed away on 2nd April, 2020. He was a true aeromodeller and historian. He will be missed by many around the world.



**VALE DON HOWIE.**

Click this link to view a visual tribute to the life of Don Howie compiled by Pete Leaney and Trevor Pearce.  
<https://www.youtube.com/watch?v=H7OXPkaByLA&feature=youtu.be>



**DURATION  
TIMES**

Duration Times is the official Bulletin of SAM 1788  
**SOCIETY OF ANTIQUE MODELLERS OF AUSTRALIA INCORPORATED**

**SAM 1788 Executive 2019-2020**

President:	Peter van de Waterbeemd	35 Cosham Close, Eden.	NSW 2551.	02 6496 4769
Vice President:	Peter Scott	44 Ravel Street, Seven Hills.	NSW 2348.	02 9624 1262
Secretary:				
Treasurer:	Paul Farthing	"Bogwood", 55 Lockwood Rd, Canowindra.	NSW 2804.	02 6364 0264
Committee:	Jim Rae 02 6495 3530,	Basil Healy 02 6651 6563,	Anthony Vicary 0458 723 073	
	Email for Australian Thermaleer - waterbee@bigpond.com			



### From the SAM 1788 President Peter van de Waterbeemd

Many events have transpired over the last three months but sadly few of them involve model flying. On Facebook, I have observed a great deal of model building with many modellers dragging old projects and kits from the rear of the shed and commencing, and indeed, completing projects. Frustratingly there have also been photos and videos of

model flying from around the world with quite a number of those from Queensland! Lucky devils.

Restrictions may ease in the near future and I believe that flying will be back on the agenda. With this in mind I am very confident that our Coota Cup will be run on 4 to 6 September followed by the rescheduled 38<sup>th</sup> Championships from the 7<sup>th</sup> to the 12<sup>th</sup> of October at the Adrian Bryant Field in West Wyalong. After that will be the Golden West Old Timer Weekend in Parkes (Nelungaloo actually) in November 14 and 15. There are ads for all three events in this issue.

The Coota Cup will be run on the State Field at Cootamundra over three days with five official events counting toward the Coota Cup. As usual it will be catered on Saturday and Sunday for breakfast and lunch and onsite camping is available. This will be our first event since Orange, an interlude of seven months.

Our rescheduled 38<sup>th</sup> SAM 1788 Championships will be held at West Wyalong from the 7<sup>th</sup> to the 12<sup>th</sup> of October and will follow the same format as our usual Easter Championships at Bogwood except that all functions will be run at the Adrian Bryant Field. This includes our AGM scheduled for Friday 9 October at 8 pm.

Last competition for the year will be the Golden West Old Timer Competition at Parkes on November 14 and 15.

All of the above is of course, still subject to the Covid 19 pandemic and to the whims and foibles of some state premiers. We can but hope - but unfortunately, hope is not a plan.

Memberships are due. Members will have received a membership renewal form via email. Please send your fees AND the registration form to the treasurer. Those members affiliating to the MAAA through SAM1788 are encouraged to do so well before the end of July so they can take advantage of the reduced fees. Remember though that we have to register you before 31 July so we need your registration well before. Recognise that snail mail has all but died.

There are now around two months before the Coota Cup so you have plenty of time to check, test and trim out at least five models. Cabin Scramble models don't need any of the above so you can just bring yours and we will try to get the numbers up in this event.

Keep Safe and keep your distance.

Peter van de Waterbeemd, President



### 38<sup>th</sup> SAM 1788 Oldtimer Championships

Wednesday 7<sup>th</sup> to Monday 12<sup>th</sup> October 2020

at the

Adrian Bryant Field, West Wyalong

- A complete program of R/C Old Timer events will be flown as per Section 5 of the 2017 MAAA rules. As there is a 2000' ceiling on this field, fuel allocation and engine run times may be limited for some events. This will be determined at the pilot's briefing prior to the event.
- Additional events include Vintage Free Fright, Cabin Scramble and Phantom and KK Champ Control Line racing.
- Registration will be on Wednesday, note this, Wednesday. Models will be scrutineered at Registration so bring your model plans. A flying fee of \$25 per flyer for the week has been levied by NSWFF and this is to be paid via the entry form.
- Competitors must be a SAM Chapter members.
- Current MAAA membership cards must be shown by all flyers.
- AGM is at 8pm on Friday 9<sup>th</sup> October at the West Wyalong Field.
- There will be a Swap Meet at 6:30 pm on Saturday 10<sup>th</sup> at the Camp Kitchen. Bring all your pre-loved gear and your wallet! Most swaps involve swapping money for goods.
- Presentation Roast BBQ and Raffle, Sunday 11<sup>th</sup> at 6:30 pm at the rear of the house. Roast BBQ tickets at \$20 per person to be paid for via the Entry Form. This will give us numbers for catering.
- On field camping including hot showers and power is available. \$10 per van or per camp per night.
- A note to those persons who registered for the competition in April. A new registration is required to be completed and forwarded to Dave Brown for this postponed competition. Cheques previously sent have not yet been presented. Fee adjustments will be made at registration.
- A requirement for control line racing. The events will be flown over the new bitumen hard surface. This surface can be badly degraded by diesel fuel, so it is mandatory that all filling of tanks and the starting of diesel engines be over a cardboard sheet. This sheet must be thick enough to absorb all fuel and spills and large enough to capture all spray and exhaust.
- The format of this 38<sup>th</sup> Championship Competition is basically the same as our previous Championships other than Registration is on Wednesday and all events and activities will be at West Wyalong. Daylight hours will be longer than they would have been at Easter so there is plenty of time to complete all flying.



Invitation by the Society of Antique Modellers of Australia  
**SAM CHAPTER 1788**  
 to the  
**38th SAM 1788 Old Timer Championships**  
 At the Adrian Bryant Field, West Wyalong



**38th SAM 1788 Old Timer Championships**  
 Adrian Bryant Field, West Wyalong  
 7<sup>th</sup> October to 12<sup>th</sup> October, 2020  
**Competitor Details and Entry Form**

**Program of Events - 2020**

**Wednesday 7 October**

Sign in. Processing, Test, Sport Flying, RC Trimming ..... West Wyalong

**Thursday 8 October**

8 am to 11 am Free Frigate Vintage (See Peter Scott) ..... West Wyalong  
 8 am to 12 noon Control Line Phantom and Champ Racing ..... West Wyalong  
 2 pm to 5 pm R/C Old Timer Glider ..... West Wyalong

**Friday 9 October**

9 am to 9:30 am R/C Cabin/Sports Model (designed before 1960) Scramble ...West Wyalong  
 10 am to 1 pm 1/2A Texaco ..... West Wyalong  
 2 pm to 5 pm Nostalgia ..... West Wyalong  
 8 pm sharp SAM 1788 Annual General Meeting (Lucky door Prize) ..... West Wyalong  
 Either in the House or in the Camp Kitchen

**Saturday 10 October**

9 am to 1 pm Gordon Burford Event ..... West Wyalong  
 2 pm to 5 pm R/C '38 Antique ..... West Wyalong  
 6.30 pm Buy, Sell & Swap Meet at Camp Kitchen ..... West Wyalong

**Sunday 11 October**

9 am to 1 pm O. T. Texaco ..... West Wyalong  
 2 pm to 5 pm Duration ..... West Wyalong  
 6.30 pm Presentation, Roast BBQ at rear of House, ..... West Wyalong  
 Toast to absent friends and Raffle

**Monday 12 October**

9 am to 12 noon 2cc Old Timer Duration ..... West Wyalong  
 1 pm to 4 pm Standard Duration ..... West Wyalong

**NOTE:**

As per arrangements at Canowindra, there will be no on field catering at lunch during the competition. Flyers and assistants will need to provide their own lunches on all days.

There will be a Presentation Roast BBQ on Sunday evening at the rear of the Farm House. This is a BYO drinks BBQ but remember there may be a drive back to West Wyalong for some. There is a \$20 charge per person for this meal.

A flying fee of \$25 per flyer has been levied by NSW FF for the use of the field for the week. As this is a new venue, this is a new charge.

Every competitor is asked to re Register for this competition. Registrations for the April event will be discarded. A reduced Registration Fee of \$15 includes a donation of \$5 to West Wyalong Hospital. For those flyers who have already paid for the postponed April event, we will make adjustments on an individual basis during registration. Note that cheques for the April Championships have not been presented.

There is on field camping available with power and hot water, \$10 per van per night.

**\*\*Important:** For the Presentation BBQ, if you have any special dietary requirements could you please let Peter Scott know well in advance so he can negotiate with the caterer.

Name: ..... SAM No: ..... MAAA No: .....  
 Address: ..... Postcode:.....  
 Phone No: ..... (home) ..... (work) .....(mobile)  
 Email Address: .....

**FUN EVENTS**

(Please tick events - No entry fees)

..... Vintage Free Frigate  
 ..... C/L Phantom/Champ Racing  
 ..... R/C Cabin Scramble

Frequency:.....

**R/C OLD TIMER EVENT Frequency**

(Please tick Events and supply Frequency )

..... R/C Old Timer Glider .....  
 ..... 1/2 A Texaco .....  
 ..... Nostalgia .....  
 ..... Gordon Burford Event .....  
 ..... O. T. Texaco .....  
 ..... R/C '38 Antique .....  
 ..... Duration .....  
 ..... Standard Duration .....  
 ..... 2cc Old Timer Duration .....

**Models will be Scrutineered at Registration. Please bring your models and their related plans.**

**COMPETITOR'S OFFICIAL STATEMENT OF AGREEMENT:**

I agree to abide by the R/C Old Timer Rules as set out in the MAAA Inc. Official Rules, 2017, and any local rules or requirements laid down by SAM 1788. I agree to compete in a sportsman-like manner and to accept the Contest Director's decision in any matter arising out of the conduct of this Championship including directions regarding height limits. I am a fully paid up member of an MAAA Inc. club and also a financial member of a SAM Chapter. If you are not a member of a SAM Chapter you can join SAM1788 for \$20 at Registration

**YOUR CURRENT MAAA MEMBERSHIP CARD MUST BE PRODUCED AT REGISTRATION.**

SIGNED: ..... SAM CHAPTER: .....

**ENTRY FEES and BBQ TICKETS**

**\*\* Presentation BBQ Tickets**

must be pre-paid for catering purposes

Registration Fee \$15 plus \$25 NSWFF \$ 40.00

Presentation BBQ Tickets\*  
 ..... @ \$20 each ..... \$

Event Entry Fees:  
 (Maximum Event Fees \$50 - Juniors are Free)  
 No. of Events ..... @ \$10..... \$

**TOTAL FEES ..... \$**

Please make cheques payable to SAM1788 or Direct Deposit to BSB: 032 527 Account: 144170 Use your MAAA number as the deposit reference.

**CLOSING DATE FOR ENTRIES Friday 2 October, 2020**

Send Entries with payments to: Dave Brown  
 Entries Coordinator  
 31 Lane Street  
 WALLERAWANG NSW 2845

Direct all Enquiries to Dave Brown - Telephone Home: 02 6355-7298 Mobile: 0402 868 568





## Control Line Racing at SAM1788 Championships

Control line Racing at the upcoming Championships will be run on Thursday morning from 9am to 12 noon in its own exclusive time slot.

The classes and engine rules which apply at the Championships are detailed below:

### Keil Kraft Phantom - Two Classes:

**Class 1-** Side port Diesels up to 2cc as per the current Class 1 rules.

**Class 2-** Any production plain bearing Australian or British diesel, up to 1.5cc.

Any plain bearing Taipan/Burford engine up to 1.5cc produced before 31/12/1970.

British Engines: Frog 1.5/1.49cc; Elfin 1.49cc; AM15; ED Hornet, Allbon Javelin; DC Sabre; ME Snipe or any other British engine produced before 1970 and approved by the SAM 1788 committee.

**The old Phantom Class 3 and Class 4 were phased out for 2019.**

Note that it is a requirement for Phantom models that the engine is securely tethered to the control system with steel wire.

### Keil Kraft Champ - Two Classes:

**Class 1-** Any Australian or British engine, or replica thereof, up to 0.8cc produced before 31/12/1970. The MP Jet .6cc is included for historical reasons.

**Class 2-** Any Australian or British engine, or replica thereof, up to 1.0cc produced before 31/12/1970.

### The event rules for all classes are quite simple:

- ) The control lines are to be not less than 35' in length measured from the front of the handle grip to the centre of the model.
- ) The model is timed over 12 laps from a standing start.
- ) Each model has three timed flights with the lowest time to count.
- ) A competitor may enter more than one model in an event, but a model may not be entered by two or more competitors.
- ) An entrant may elect to have the model flown by another person.
- ) The engines in Phantom models are to be securely wired to the control system with steel wire.

### Requirements for control line racing at the Adrian Bryant Field:

The events will be flown over the new bitumen hard surface. This surface can be badly degraded by diesel fuel, so it is mandatory that all filling of tanks and starting of diesel engines be over a large cardboard sheet. This sheet must be thick enough to absorb all fuel and spills and large enough to capture all spray and exhaust.

## Suggested Old Timer Rule Changes proposed by the SAM 1788 Committee Meeting at Orange 2<sup>nd</sup> February 2020. Report from Peter Scott.



**Present:** Jim Rae, Peter Scott, Basil Healy, Anthony Vickery, Paul Farthing.

### 1/2A Texaco:

Change engine eligibility to any .049 Glo engine - non schnurle - produced before December 31<sup>st</sup> 1979. Fuel tank to be as .049 Baby Bee small tank.

**Reason for change:** Some fliers are not participating in 1/2A Texaco as they are fed-up with the sometimes fickle operations of the Cox reed valve engine. The Cox engine, in fact, out-performs most other engines of this period, so apart from ease of handling there is no big advantage one way or the other for this change except to make it more attractive to non-Cox lovers.

### Burford Duration:

All engine runs to be 30 seconds, both PB or BB engines, any capacity up to 2.5cc.

**Reason for change:** To lower the end of climb height. The 5 minute max is still easily attainable.

### Old Timer Duration:

Engine run times: 20 seconds for 2 stroke schnurle engines;  
32 seconds for Standard four-stroke engines;  
28 seconds for supercharged four-stroke engines;  
32 seconds for Spark engines.

**Reason for change:** These changes should reduce height at the end of the engine run and even out the big McCoys etc. advantage over the rest. The spark engines will, when running properly, still out-climb all the others, but not by as much.

**Texaco:** No change.

**'38 Antique:** A committee set up to slightly adjust engine runs that, in some cases, are too punitive and, in other cases, give unfair advantage. Many people choose an engine that should really be a step up in class and some engines really deserve a longer run. It should be noted that most engines are in an appropriate class.

**Nostalgia:** No change.

### 2cc Oldtimer Duration:

Engine Run Times: 30 seconds for Diesel engines;  
25 seconds engine for Glo engines (any fuel).  
Cut-off date for Glo engines December 31<sup>st</sup> 1970.

**Reason for change:** Only change is to Glo format as at present there is no point in using them. This should encourage more participation.

**SAM1788 Competition Calendar for 2020**

- August 28-30**    **Cowra Oily Hand 2019 - Cowra**  
**Events:**  
 Various events plus SAM1788 Cabin Scramble  
**Contact Person:** Andy Lockett 02 63423054
- September 4-6**    **Coota Cup Old Timer Weekend - Cootamundra**  
**Events:**  
 Friday pm: Old Timer Glider  
 Saturday: Gordon Burford, Antique '38, Duration  
 Sunday: Cabin Scramble, 1/2A Texaco, Texaco  
**Contact Person:** Peter Scott 02 9624 1262
- October 7-12**    **SAM 1788 38<sup>th</sup> Championships - West Wyalong**  
**Events:**  
 All 9 MAAA Old Timer Events  
 plus Cabin Scramble and Control Line.  
**Contact Person:** Peter van de Waterbeemd 0412 632 470  
 See Official Program herein for details
- November 14-15**    **Golden West Old Timer Weekend - Parkes**  
**Events:**  
 Saturday: 2cc Duration, Gordon Burford, Duration  
 Sunday: Cabin Scramble, 1/2A Texaco, Texaco  
**Contact Person:** Paul Farthing 0427 640 264



*Would be a little wet under foot at Bogwood Farm Canowindra if the 38th 1788 SAMChamps were held. Very wet and windy over Easter. I (Condo) remember wading in that dam years ago to collect Don Southwell's 1/2A Stardust Special.*



**Cootamundra Old Timer Weekend**  
**The Coota Cup**  
**4 to 6 September 2020**  
 at the  
**State Flying Field, Cootamundra**

**Friday 4<sup>th</sup> September**  
 1:00 pm Oldtimer Glider

**Saturday 5<sup>th</sup> September**  
 9:30 am Gordon Burford Event followed by Old Timer Duration

**Sunday 6<sup>th</sup> September**  
 9:15 am Cabin Scramble, 10:15am 1/2A Texaco then Old Timer Texaco  
*All events will be run to MAAA 2017 rules.*  
*MAAA membership card to be shown.*

Catering Saturday and Sunday for both a hot Breakfast and Lunch  
 There is on field camping but no power.  
 Hot showers are available generally on Saturday and Sunday or whenever  
 the generator is running.

Information: Peter Scott 02 9624 1262 [qualmag@optusnet.com.au](mailto:qualmag@optusnet.com.au)

<b>FOR SALE</b>	Ignition coil assemblies with transistor - ready to go. \$70 <b>Peter Scott</b> (02) 9624 1262. <a href="mailto:qualmag@optusnet.com.au">qualmag@optusnet.com.au</a>	<b>FOR SALE</b>
-----------------	--	-----------------

From Canowindra.....  
30th SAM Champs, 2012.



I'm not silly - I used the boat  
..... Paul Farthing



Why I now hate 1/2 A Texaco ... Condo



The DAM Photos



Bob and Dot Rowe on the occasion of being made a  
Life Member of SAM 1788 at Muswellbrook, 2003.



Maria Coutsos and its mentor  
Tom Tobin. November 2003



ABOVE: Past SAM Champion Bruce Knight enjoying a flight  
at the 2006 New England Gas Champs, Tamworth,  
joined by old friends Dave Paton (Qld) and Basil Healy.  
Photos by Karen Payton.

# Vale Beryl Southwell

Beryl was well known to all modellers on the flying field. She accompanied Don for many years and was always there to assist. When on many occasions, Don was contest director for an event, Beryl would be entering the times on the score sheet and keeping careful tabs on how far the event had progressed and which flyer was holding up progress at the end of a round. Beryl would always be pleased to time for anybody who asked.

Beryl was always beautifully dressed and smiling, like the ray of sunshine she was. When not scoring or timing she would flit about talking to all, concerned about their wellbeing and making her witty observations. She especially liked to sidle up to Dave Paton and cheekily ask him what it felt like to be beaten by a twelve year old girl in Texaco\*. Beryl was undoubtedly the "mother hen" on the field.

Don and Beryl Southwell with Don's Thunder King at Walkerie Nats, 1992



Beryl was very much part of the ladies table at the annual Championship Presentation dinner. This was a strictly a ladies group and goodness



knows what and who was discussed in that sacred space. Better we men don't know.

Beryl was very proud of her family and always had some photos to show. She was, I believe, most proud of Don and his many achievements. Especially so when Don won Crookwell's Citizen of the Year in 2018 for his "outstanding contribution to the community". She showed all of us the



newspaper article and photos.

Beryl will be sadly missed by all SAMs flyers.

\*This was Sarah Wright at Canowindra in 2012 but in Dave's defence, Sarah in fact placed ahead of forty male Texaco flyers.

Next page are Don Southwell's own comments regarding Beryl, his wife of sixty years. I felt that they were best left as is and not incorporated into my article.

All photos by Karen Paton. Peter van de Waterbeemd



Beryl & Don Southwell

### BERYL and SAM 1788

From Don Southwell.

Beryl's long involvement with SAM 1788 began in 1987 when we visited "The PINES" to see what Old Timer flying was all about. From then we became regular visitors to Canowindra staying at various locations including sharing a rented home with Ian and Dianne, at Balloons Aloft in rooms then with the caravan, finally staying at the Old Vic.

During these times we met new friends from all over Australia, when later with the caravan, while visiting all states except Tasmania to compete at the Nats, we were able to renew these friendships.

Beryl's duties at the field included:- recording results, time keeping, cleaning the plane after events, walking the pits to meet and greet. Off the field, before the weekend Beryl planned the food, packed the clothes to ensure that I was correctly dressed and always looked forward to meeting up with the girls of the Family of Flyers to share the latest news. Her acceptance was recognised with the request "Beryl will you time for me?"

Her only comment regarding the electric flyers was that their conversations were too technical, but she was a timer at the Electric World Championships when held at Wangaratta.

Flying advice from Beryl included:- keep it up Don, do you know what plane you are flying, don't forget you have to get it back, if it gets too high you won't be able to see it, don't worry you can build another plane. To an unnamed flyer she asked, "Dave, what's it like to be beaten by a girl?"



For me, Beryl gave inspiration and support with her only disappointment being those friends that are no longer with us.

A warning to all flyers, Beryl now has a new stop watch and will keep check from above.

Two Photos from Fiona



### Golden West Old Timer Competition - Parkes Parkes Miniature Aero Club Inc. - Nelungaloo Field. 14<sup>th</sup>-15<sup>th</sup> November, 2020

Saturday: 9:15 Start: 2cc Duration, Gordon Burford, Duration

Sunday: 9:15 Start: Cabin Scramble, 1/2A Texaco, Texaco.

*All event to be flown to MAAA 2017 rules.*

*Note: Modelers must produce a current MAAA membership card.*

**Get together in Parkes on Saturday Night**

**\*\* On field catering all day and camping on field  
(\$10 per adult per night)**

(Campers please note - power, toilets, hot showers available in the amenities block)

# FOR SALE

**Vin Morgan Tracking System  
Two Transmitters (model) with One Receiver.**

As new. \$350.

Contact: Roy Summersby

Phone: (02) 43410072 or Mobile: 0413 588 720.

Email: [roydi132@optusnet.com.au](mailto:roydi132@optusnet.com.au)

## Condo's Old Timer Model Page from Facebook. 31st May

G'day, Most Old Timer Flyers in Australia will know Don and Beryl Southwell.

I am sad to report the passing of Beryl. May she rest in peace. At time of her passing Don was in hospital having surgery.

During the early years of my Old Timer Flying, when ever I made a fly off Beryl would come and time for me, whether it be at a club comp, MAAA Nationals or a SAM 1788 event, she was always there to time for me.

Beryl's friendly smile and gentle gracious manner will be sadly missed by me and others who knew her and Don.

We all wish Don a speedy recovery and offer our heartfelt condolences to him and his Family.

Condo.



## Oily Hand COVID-19 Update as at 21st April 2020.



Hello Oily Handers,

We have been fielding inquiries from far and wide about our plans for this year's OHDD.

As of today we have made a decision that Cowra MAC will plan to go ahead with all the organisation and planning as if Oily Hand will run as normal on Friday 28th, Saturday 29th and Sunday 30th August 2020.

Of course we are all in uncharted waters and we realise that anything can happen between now and then.

So in the first half of July a final decision will be made based on the situation around us at that time.

This leaves time for booked accommodation to be cancelled and organisation to cease.

A postponement would only be till Oily Hand time next year. That would be 27th, 28th & 29th of August 2021.

At this stage we have decided not to run an alternate 2020 date as we anticipate that the aeromodelling calendar post Corona restrictions will be full.

If a date can be found we would run a low key gathering for Oily Handers.

If we decide to postpone you will be notified if you are on the email list. Notice will also be posted on the Cowra MAC website.

Keep safe and well so we can all keep on Oily Handing once this has passed.  
Andy Luckett Oily Hand Day co-ordinator.

### 'Models of the Meet' for 2020 should it go ahead

Prior to Covid-19 we were getting a few queries about Model of the Meet for 2020. So we have made a few decisions.

**The C/L models** are the Carl Goldberg series of profile stunters: Shoestring, Cosmic Wind and Buster.

You would remember Dave Bailey had his very nice Shoestring on display and flying at Oily Hand for us in 2019.

These are the 42" profile fuse series based on full size pylon racers.

Be careful as there are full fuse and larger versions around and they are not part of model of the meet. Only the ones from the original Goldberg series are valid for this event.

Of course you can scale from the original plan to build smaller and larger versions. The Shoestring plan is available on Outerzone. The Cosmic Wind is on Hip Pocket. I haven't seen a plan for the Buster. Brodak does a kit of each complete with decals.

**The R/C - F/F model** is the Aeroflyte Nova. This is a pretty 46" span parasol wing three channel model.

**UPDATED INFORMATION REGARDS THE "NOVA" FOR OHDD 2020** (should it go ahead)

The foreshadowed kit that was to be produced did not eventuate. I have it on good advice that the factory was destroyed by fire.



Nova (oz5582) from Aeroflyte

The plan on Outerzone shows templates for various parts including the formers, cabanes, doublers, fin, tail & etc. This is really useful as it will make setting up the cabane and wing incidence easy. The Barnstormer from a couple of years back proved a bit tricky in that area.

There has been discussion about the engine to power the model. As the model was a from a popular Australian manufacturer and the plan showed an OS 15 glow engine it has been decided that as well as a diesel, a glow engine is also allowable. Therefore, the engine for the Nova can be a diesel of any capacity or a plain bearing glow engine with a maximum capacity of .25cuin. It may be fitted with the stock muffler supplied with the engine.

This allowance is only for **THIS** particular model.

**ALL OTHER R/C models at Oily Hand must follow the Oily Hand engine formula. That is, any size diesel or a glow of less than 1cc.**

This will mean that after Oily hand the model can be flown at fields with noise restrictions.

We anticipate this will encourage a lot more modellers to build this fine little aeroplane. Remember you can scale the model up or down and add ailerons if you wish. But, keep the outlines and sections the same.

**R/C POWERED AIRCRAFT**

165 NOVA 1160mm span 3 channel .15ci (2.5cc) engine R/C sports kit. Parasol wing, stable flying characteristics and good looks make it an excellent choice for sports flyers. Can be flown as 2 channel model with fixed engine speed.



**How come all Novas turn out yellow? By Andy Luckett**

This Nova was built about 23 years ago from the Aeroflyte kit. It has lounged around in the roof cavity of the house in the intervening years. The model flies nice and smooth and is responsive to rudder. Originally powered by an OS .15

which made it too fast at full throttle. Was later fitted with an OS.10 which was adequate power. Needs a good dust off and some refurbishment. The paint has cracked and blistered. The aim is to fit a PAW 1.5cc.



Andy's original Nova, built for his son Owen because he liked to look of the piccy on the box. Taught him the first steps in radio control flying. Nice and smooth if not overpowered.

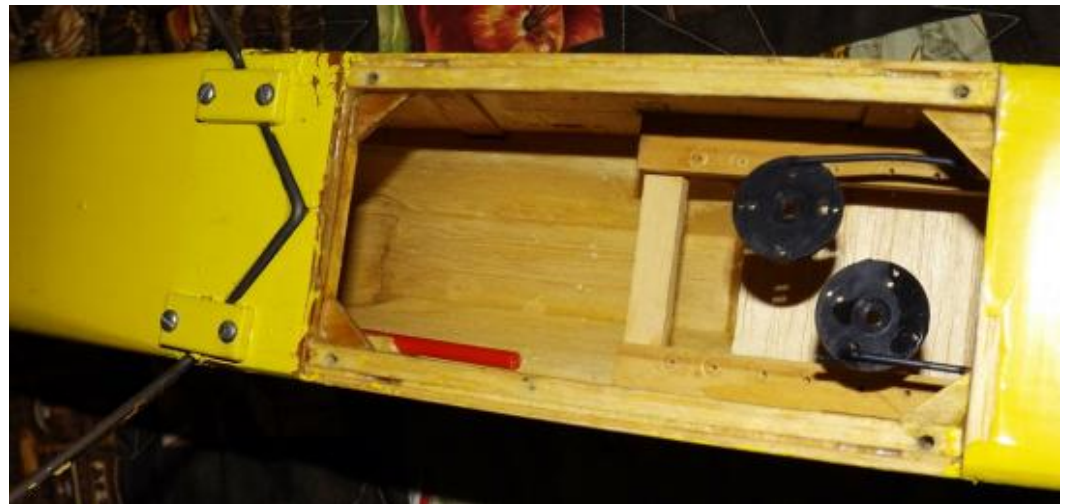

The hatch is on the underside of the fuselage. Notice how the front turtle deck was built up from quite substantial sheets of balsa (section E-E on the plan). Also, how the landing gear is recessed into the lower fuse and held by flat clamps. The U/C fairings and wheel pants have long gone. In a cupboard somewhere there is a mould taken from the ABS wheel pants.

## The Ramblings of an Ancient Aeromodeller

Basil Healy.

Having pursued the building and flying of Old Timer model aircraft for far longer than I did the other facets of aeromodelling, I thought it would be a good time to share some of the knowledge acquired along the way. With a blanket ban on flying no doubt many of you will be concentrating on building and refurbishing so hopefully may find some of the following to be of interest.

### Visibility of Models at Height.

Having recently had cataract operations on both eyes I was keen to try them out at Canowindra at Easter. Alas, this was not to happen due to the cancellation of the SAM Championships. For some time I had been noticing that models covered with transparent or semi-transparent covering were more visible when flying away from the sun than when flying toward it. This prompted an experiment at home with wings from my Lanzo Stick and Record Breaker. Both wings were covered with Polyspan. The Lanzo stick was finished in clear dope and the Record Breaker in yellow dyed dope. The experiment was carried out at about 3.30 in the afternoon, about the time that most fly-offs occur, with the sun at a relatively low angle above the horizon. With the leading edge pointed away from the sun there was little difference in the luminescence of the two wings when viewed from below when positioned at a couple of degrees nose up. However, when pointed toward the sun the Record Breaker wing was markedly brighter. How can this be? Having dye in the dope means there must be less light transmitted through the wing than more! The answer lays in the method of construction. The Lanzo Stick wing has a sheeted leading edge but the Record Breaker wing only has a couple of small spars on the top forward of the main spar.

The upper surface of the Lanzo Stick wing was in shadow from the leading edge sheeting but the Record Breaker wing admitted light between the spars making the lower surface look much brighter. I had observed this same phenomena when timing other peoples too.

Needless to say none of the above applies if you use solid coloured covering on your models.

### Does Balsa Deteriorate with Age?

On three occasions recently I discovered cracks in the fuselage of my Nostalgia model while checking it over shortly before an upcoming competition. In each instance I will swear that they were not there when I cleaned it and checked it for damage prior to placing it up on the shelf ready for it's next outing. Closer examination revealed that the balsa was crumbling in any spots where the dope and fuel proofer had worn off. Any flexing of the structure was accompanied by creases and cracks as more splits appeared. Clearly, the balsa had dried out and become brittle!

Now, my Nostalgia model is 12 years old, it only gets flown about three times per year so it has not spent much time out in the sun. However, in my previous house it



spent a lot of time stored in the garage roof space which was open to the house roof space and gets mighty hot in summer (40 degrees plus at times). This treatment had no doubt reduced the moisture content of the balsa rendering it brittle. While the outside of the fuselage was doped and fuel proofed there was nothing to stop the moisture from evaporating from the inside of it. No problems were noted with the balsa in the wings and tailplane. I suspect that this was because the covering retained the moisture within the structure.

This lead me to think back to my earlier days in the aircraft industry when I was once asked to check the moisture content of a large spruce log prior to it being cut up to make replacement spars for a Tiger Moth. This was done by cutting a sample piece from the log, machining it to 12" x 1" x 1" and then weighing it on a chemical balance.

From this the weight per cubic foot could be determined. If this fell within the specified range (about 28 pounds per cubic foot), the piece was then baked in a pie oven (we were real low tech in those days) for 24 hours then weighed again.

The difference between the two weightings represented the moisture content. The optimum was around 15%. Any higher and the log was returned to the timber store for re-checking at a later date and any lower and it was down graded for use on secondary structure only. Spruce reaches its maximum strength and flexibility at 15% moisture content. To try to maintain this figure once it has been embodied in an aircraft structure it is varnished thereby trapping the moisture within it (hopefully).

So, what is the fix for my problem? Primarily, don't store your models in hot, dry places. I have read of models in England being discovered in attics 70 years after they were last flown having their covering renewed and flown again. No doubt a cool climate and a higher humidity level contributed to their survival. Meanwhile I am building a new fuselage for my Nostalgia model.



# RC1

A

## "PLANE FOR ALL SEASONS"

From Peter Scott

The person who may wish for the simple model to build, a model that's easy to transport - yet can fly in several contests and, with luck and good air, and a reasonable pilot, be right in the picture.

The trick of all this is to build wide as possible engine bearers. This allows an alloy plate held in place by six screws to slide in place to carry the motor of your choice, complete with fuel tank.

My model has coil ignition which fits conveniently in the front of the cabin, and with a spade connector to the points, can be connected to any spark motor at the drop of a hat. One simple fuel shut off controls the ignition cut off switch and the fuel shut off for those that fancy a diesel.

For Antique, a range of spark motors can be fitted, or a good 5cc diesel will do the job. I have used a Burford 5cc diesel, which can also be fine, with no changes, for Texaco. I have used several spark motors. I get a 4mins engine run with a Whirlwind spark on methanol. One could easily use a Frog 500 spark, Brown junior, the list goes on!

The Texaco option can be the diesel as stated previously, or a reliable spark motor running on petrol with a 16" prop.

This model can also be used in Duration. A decent McCoy 49 on spark pulls this fairly low drag model up a long way on 40secs. The wing area rule means no 60's, but the 49 McCoy fits the bill.

So, one model for 3 contests, motor change in 5mins. What's not to like?



**A BIGGER BOMBER - 200%****Part 1 From Peter van de Waterbeemd.**

For many years I have always wanted a big model - not just a model with a large wingspan but a model that was simply big. The idea for a BIGGER Lanzo Bomber started a few years ago when I decided that because I have always liked the Lanzo Bomber, this would be a worthwhile project as a large model. I knew that it would not be eligible to fly in any Old Timer event but that was not a consideration. I knew that BIGGER would fly better and it would look BIG! In March it presented itself as an ideal isolation project whilst we were all confined to jail by our political masters (?) for a crime which we did not commit. 'Nuff said!

A standard 100% Bomber has a 96" wing span when laid flat out but it is around 90" when assembled measured from tip to tip. A 200% bomber would be 180" tip to tip which is around 4.5 metres. Other interesting statistics are a tail span of 73" or 185cm, a fuselage length from firewall to stern post of 91" or 231cm, a rudder which is 29.5" or 75cm high and a pylon which is 10" or 25cm high and 28" or 72cm long. The chord of the wing is thus 28" or 72cm. What will the all up weight be?

There has been some discussion on the engine, specifically what size should it be? Given that the model is twice as large as the original, it will have four times the wing area and eight times the overall volume. We know that a standard Texaco Bomber will fly on a four stroke 60 swinging a 16 x 8" prop at around 5000 rpm. So, what size engine for the BIGGER Bomber?

I momentarily was drawn to the dark side but no noise was not an option. I happened to come across an OS 200 FS (about 33cc) at the right price and hoped it



might do the job. I think it will be good enough as some weeks ago a friend at the Bega club was flying a 1/3<sup>rd</sup> scale Avro Avian 616 with a 112" wingspan on a four stroke NGH G38 38cc petrol engine and that was performing very well on half throttle. My logic is that two wings of this biplane have roughly the same wingspan and area as the BIGGER Bomber, and the Avro Avian is aerodynamically dirty (lots of drag) compared to a Bomber. So, the OS 200 FS ought have enough power. Still, the proof will be in the first flight.



I started on the tailplane followed by the elevators and the fin/rudder. For the building plans, I selectively enlarged the curved parts of the tail and fin/rudder (using the 200% enlargement feature on my Canon printer and then gluing lots of A4 sheets together) and but for the tailplane I marked out the position of the ribs on the spars. That was enough to build the tailplane. I intend to use the same procedure for the wing. The fuselage was assembled by marking the "station" positions on the longerons and building the sides from these marked positions. No fuselage plan was drawn.

**Tailplane:** Building with the tailplane brought out some issues. Lesson number one, nothing is easy at this size and you cannot just use a double size of anything and expect it will be OK. Weight becomes the first obstacle. I used the same spar layout as the original tailplane and ripped 1/2" by 1/4" Queensland Hoop Pine (QHP) spars. In hindsight they are too heavy and maybe hard balsa would have been strong enough over the 73" span. For the rear spar of the tailplane I originally used a strip of 6mm by 43 mm QHP. Also too heavy so after the tailplane was built I ran it over my saw bench and trimmed the rear spar to 4mm thick. Still too heavy so I cut holes down the centre length of the spar. Getting lighter but it still ended up around 750gm. Interestingly, each elevator half is 80cm by 25cm, each about the same area of my 1/2A Stardust Special wing.



**Fin/Rudder:** The fin and rudder were built over the enlarged plans. The lines on this plan were now also double width but I ignored this as it really doesn't matter if these components are a millimetre too large or too small. This model isn't going to be scrutinised by the fun police. The original used 1/4" balsa and because of the very large areas for these pieces they were made from 1/2" balsa and paulownia.

The fin/rudder was made to be removed from the tailplane using the system used by Geoff Potter in his Bombers. The rudder is moved by a pull-pull system with the servo in the fuselage under the pylon. The rudder horns are designed to be removed so that it minimises the risk of damage in transport. The elevator servos, one per elevator, are mounted vertically in the tailplane.

**The fuselage.** Having learned a little from the weight in the tailplane, I made the longerons from 11mm by 11mm QHP with each longeron trimmed down from the rear of the pylon to 6mm by 6mm at the end of the fuselage. All cross section pieces were from paulownia. At a couple of stations a 3mm ply former was installed to ensure the final cross section was square. When assembled with the tailplane fitted it was a disturbing sight to see that the fuselage was able to twist through

30 degrees when lifted by one end of the tailplane. The solution to stiffening up the structure was to glue a diagonal between each station on all four fuselage sides and in effect making four Warren trusses. When all four sides were complete with diagonals, the fuselage was quite rigid and virtually no twisting left. The pylon was installed and a removable fire-wall assembly built. This has the engine mount and undercarriage on the front and houses a tank bay and throttle servo on the rear.



**Electronics.** A six channel Spektrum AR6000T receiver with a satellite and a Variometer/Altimeter installed on the X-Bus is to be the control system. The distance from RX to tailplane servo was around 2.2 meters. I wondered how long a servo extension lead could be and went to RC Groups to see if there were any suggestions. Consensus was that twisted, heavy duty servo leads be used with a choke installed at the receiver end. Duly installed.

I will also be using two flight batteries (probably 2000 mAh NiMH) each connected through its own switch, one to the battery port and the other to a spare port on the receiver. This protects against a single battery or single switch failure.

**Wheels.** The original had 3.5" wheels and so 7" wheels were required. Not readily available in the market place so I have made a 6" set and a 7" set. Basically, a central disc laminated from two pieces of light 1/4" ply and lightened with six holes spaced around the disc. Larger 3mm ply discs glued on each side complete the hub.

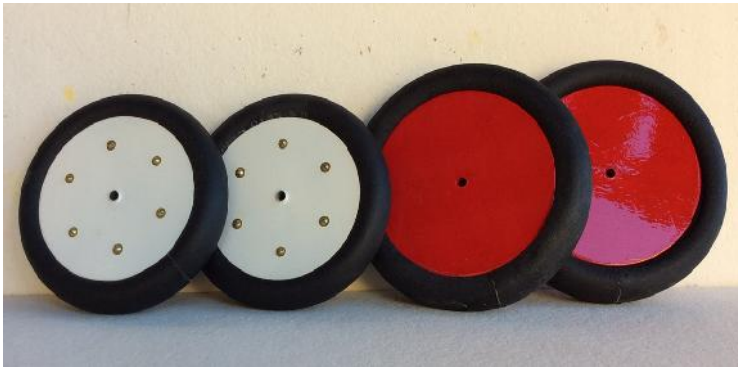

A piece of brass tubing is glued into the centre of the hub for the axle housing. The tyres are made from the black neoprene lagging used to insulate hot water pipes.

The ends were glued using contact cement to make a tyre. They are fitted over the hub and will be glued in place, probably using silicone as it is flexible. Will this work? I'll tell you after the first few landings. The wheels are removable and stored in a custom-made orange box (see photos) 'cause I was bored one night and went berserk on the bench saw. But a good job really.



**Covering.** Some years ago, my wife and I accompanied friends on a most excellent trip on a luxurious river boat down the Mekong river from Siem Reap in Cambodia to Hanoi in Vietnam. At the markets in Siem Reap I purchased twenty or so metres of silk. I was always worried that it was too heavy but I now feel it may be too light. I covered the tailplane in the silk using four pieces, two on top and two on the bottom and that went quite well - but it shows up every building flaw no matter how tiny the flaw. I hadn't realized how many building faults HobbyKing heat shrink plastic covering hides from view.

The edges of the tailplane were given two coats of Nitrate dope and when dry, water wetted silk was laid across the frame and held in place around the edges with dope dabbed through the wet silk. The secret is to keep wetting the silk until the dope has thoroughly dried and then the silk can be allowed to dry and shrink and exaggerate all building flaws. Next step is to seal the silk, but I have not, as yet, decided on the best method. Nitrate dope, butyrate dope or a water based acrylic sealant. Further discussion has brought up another possibility and this is using the silk over laminating film. This is currently being tried out on a test frame.

I was going to cover the fuselage in silk but have decided the silk may be too flimsy so a large pack (5 yards) of Koverall has been purchased and that will be used instead. A couple of local club members suggested that a water based product called Mod Podge (Google it) can be used to both glue the Koverall to the structure and also seal the Koverall. Full strength Mod Podge is painted to the edges and

when dry, a hot iron will melt the Mod Podge and attach the Koverall, the sealed with diluted Mod Podge. I will be trying this as the smell of any more dope in the house is likely to cause a divorce.

I assembled all the components for a photo and there is one glaring deviation. The main undercarriage is made from a single 36" length of 7/32" spring steel. Had it been made the correct double size, each leg should have been 30". However, there is plenty of prop clearance so it should be OK - but dammit - it doesn't look right! May have to address this.

**Wing:** The wing will be in three sections. One central panel of 96" and two removable 48" tips. Simple really. Work is yet to begin on this and that will be part two of the tale.



Any comments or (positive) suggestions will be appreciated. I cannot afford sanity testing or a psychologist so don't go there. Peter van de Waterbeemd.

### For Sale Kits R/C, C/L, F/F

All proceeds go towards improvements at the AB Field West Wyalong

R/C Playboy Senior	\$120	80" by Old Fashioned Hobbies	Good
R/C Playboy Senior	\$120	80" by Old Fashioned Hobbies	Good
R/C Lanzo Bomber	\$120	90" by Old Timer Aircraft	Good
R/C Lanzo Bomber	\$120	90" by Old Timer Aircraft	Good
R/C Lanzo Bomber	\$120	90" by Old Timer Aircraft	Good
C/L Peacemaker E/B		35.5" by Old Timer Aircraft	Good
R/C Precedent Bi Fly	\$150	48" by Balsa craft England	Good
Rolladen Schneider LS3 R/C	\$120	110" Foam wings Glass Fuse (2 fuselages one is T-Tail)	Good
R/C Giles 202	\$150	1400mm ARF	Good
2 Hangar Rats by Max Starick	\$20 each		Good
R/C Stiletto	\$50	by Dave Brown (short kit)	Good
R/C Hotdrop	\$50	by Dave Brown (short kit)	Good

E/B indicates that I am or will eBay these items

Contact Roy on 0413588720

for prices and more details

### Height Indicators From Peter Scott.

On speaking to Harry Sokol about a height transmitter with a variable setting i.e. 400ft at most club fields, up to 2000ft at authorised venues, he was convinced that there was no problem whatsoever with producing a good usable and reliable height indicator.

A small transmitter in the model will send a message to a small receiver, which can be attached to your transmitter or on your belt and will give a warning that the height that you pre-set has been reached.

This is all underway, the transmitter in the model will be specific to your receiver and each transmitter will have its own band.

I have ordered three transmitters and one receiver, delivery in the next few weeks. More details later, but this gets us over the question of how do you know how high you are at any field.

### Email from Harry Sokol.

Peter, The project advances.....

I have determined the physical layout of the ground unit and now the circuit board is done. I should get them in a week or two (corona-lag might slow it a bit) and can get on with the software phase.

The ground unit will have 2 rotary switches to set desired maximum altitude (0 - 99) in units of 10 meters = 0 - 990 meters. A 4 digit display will show the current altitude. To get altitude relative to actual location, a zero facility is incorporated. Press the zero button and all altitude display and action is with ground altitude as reference.

An adjustment for the frequency of the buzzer is available via a variable resistor (trim pot) inside case. Not a full spectrum, but adjustment around a centre of 4Khz.

A binding facility is also incorporated to allow the airborne unit to bind to a particular base station.

Integrated Lipo battery with inbuilt charger, just supply 5 volts via mini USB connector (phone charger, USB port on your computer, etc.)

Attached is a 3d rendering of the base unit.

Harry...

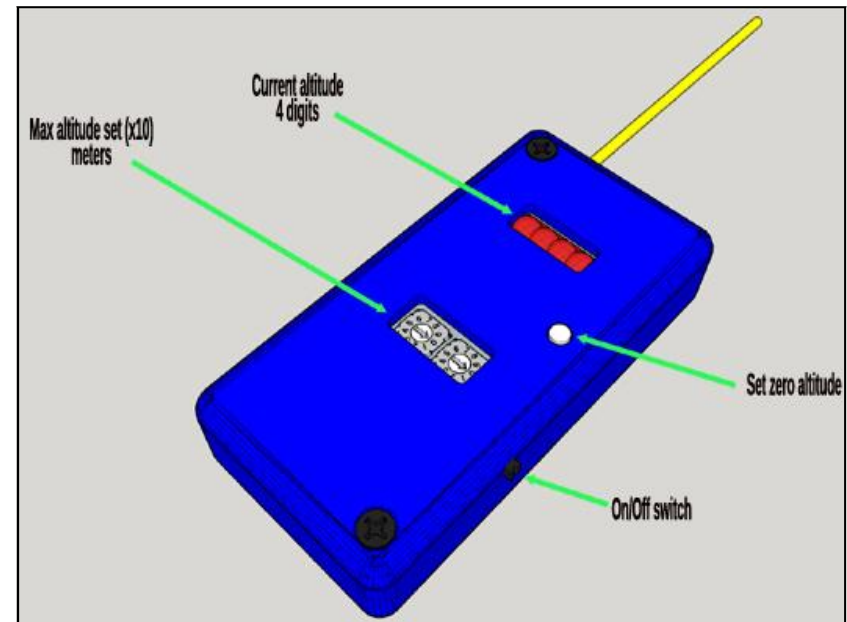

# The Geezer

Official Journal of the WA Model Aero Club (inc) and  
SAM 270 Western Australia



<b>SAM 270 Committee</b>	
President: <b>Troy Latto</b> Mobile: 0404 810 233 Email: Troy.Latto@ncr.com	Vice President: <b>Hans van Leeuwen</b> Mobile: 0419 921 693 Email: hans.vanleeuwen@bigpond.com
Secretary: <b>Graeme Cooke</b> Mobile: 0447 508 883 Email: graemecooke@bigpond.com	Treasurer: <b>Rob Bovell</b> Mobile: 0420 356 125 Email: r_bovell@bigpond.com

**Email from Hans van Leeuwen**  
hans.vanleeuwen@bigpond.com

Hope all's good your end.

Find attached an article for the next Australian Thermaleer. Not a lot there, but the best I could do given the circumstances.

Any idea where we're at with that Old Timer Special Interest Group?

I have some concerns about those rules proposals that came from Queensland and hope that things don't get stuffed up.

My personal belief is that the rules we have, particularly the Glider and IC stuff has evolved over quite a long time and while they may need a little fine tuning from time to time, they are basically workable.

What we need to do is to adapt those to the height limits set by CASA and I believe that this is possible with some technology such as an altimeter that can audibly indicate height and competitors should not be allowed to exceed that height.

If they do, there should be a penalty and I'd propose that particular flight time be cancelled.

I'll produce something that is perhaps a little more coherent on my thought on this topic. However, I'd welcome your initial comments on my rough thoughts.

Regards,  
Hans van Leeuwen.  
Vice President,  
SAM 270 Western Australia.

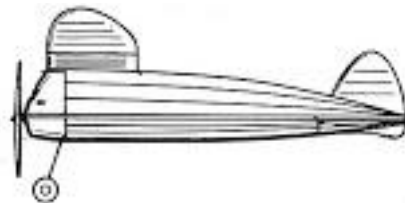

WAMAC STATE CHAMPIONSHIPS CONTEST CALENDAR 2020			
DATE	FREE FLIGHT EVENTS	OLD TIMER EVENTS	FIELD
12 Jul	Open Power		Beverley
26 Jul		Nostalgia / Burford	Beverley
09 Aug	E36/Electric		Beverley
23 Aug		Standard Duration	Beverley
20 Sep		1/2A Texaco	Beverley
4 Oct	Slow Open Power		Beverley
18 Oct		Duration	Beverley
1 Nov	Open Rubber	Old Timer Glider	Beverley
15 Nov		Texaco	Beverley
29 Nov	Combined FAI / 1/2A Power		Beverley
13 Dec		1/2A Electric / Tomboy	Beverley

Day 1, Sunday, April 30



Graeme Cooke with his newly completed Angel, a local design by Pete Sommers and built as a result of the lock-down process.



Stuart Sherlock with open power model and Steve Walton with a catapult glider.

## SAM 270 Report.

From Hans van Leeuwen.

Flying in WA has not happened for a significant time due to the Corona Vitus issue as it has all over the country I presume. So there is not a whole lot to report.

Our Club's flying field has been inaccessible since 24 March because of internal borders within our State. Most of our Club members live in the Perth Metropolitan Area and we were not allowed to cross the border to the Wheat Belt, which is where our flying field is.

Internal border restrictions were relaxed somewhat on Monday, May 18 which meant that we could go flying at our Beverley Field on Sunday May 24. However, Murphy was alive and well and while there was a possibility of flying, the weather God thought otherwise and prevented us from flying that day.

The weather forecast for the following weekend was good and it was also a long weekend for us in WA.

Four people flew on Sunday and there were 16 people at the field on Monday, two of whom were there for both days. The reason for the better turnout on Monday was mainly because the weather forecast for Monday was better than for Sunday and the proved to be absolutely correct. The weather was superb on Monday, slight drift, somewhat overcast, thus ideal for flying.

If there was any benefit of the lock-down that most of us experienced it was that quite a number of people used this time to repair or refurbish models, to finish started projects or to build models that they had intended to build but did not for a lack of time. This was evident at the flying field as well.

Day 2, Monday, June 1.



A gaggle of Madcaps, quite co-incidental, the two at the left by Chris Edwards shown with his models, the red fuselage is 1.5 times wider than standard, centre model by Noel McMillan and far left by Hans van Leeuwen.



The flight line and some of the activity.



FAI power model by Colin Crowley, sadly had fuel feed problems.





Paul Rossiter winding.

Ian Dixson flew a new Diamond Demon of which I sadly did not get a picture. Lovely build and great flyer, this augurs well for Steve Walton who is building a scaled up version for his self-built 5cc diesel engine.

There were a number of visitors who flew a variety of models and in general people seemed to enjoy the day. There was a lot of flying and, of course, the usual arm chair flying and reminiscing as well. I think that a good weekend was had by all.

In closing, all I can say is that I hope that we can now begin to enjoy our hobby and sport a little more consistently than in the time just past.

I wish everyone good flying weather and strong thermals.

Hans van Leeuwen.  
2 June 2020



## The Angel

Power Scrambler from Pete Somers Feb 1971 (from Dec 1967 Original)

By Graeme Cooke  
WAMAC / SAM 270 W.A.

As promised attached are photos and a copy of the plan for the FF Angel Scramble Model.

A fellow Modeller here in WA, Kim Parks, has been doing a fantastic job of trying to generate interest for juniors and recently circulated the "Pete Somers" 1971 FF Angel Scramble model Design in a bid to get people excited about the proposed FF Scramble event at the WAMAC / SAM270 Field near Beverley.

I studied the plan for some time, noting the simplistic, yet functional construction, I have some tissue, a few sheets of balsa, a Cox 0.049 and Dethermalizer timer laying around - so may as well get building.

First afternoon saw the construction of the airframe largely completed, just need to take the wing outside and shape it once it has dried. Second afternoon I shaped the wing, set the tip dihedral, carved the cheeks and a hole for the timer, drilled holes for the dowels and glued the fin onto the tailplane.

A couple of weeks later, I set about covering the model with tissue and dope, by far the hardest job thus far, ended up taking another half day or more.

Some warm weather over Easter provided the perfect opportunity to varnish the airframe. Left the finished airframe to dry for a week, before screwing the motor and timer into place, a few minutes to rig up the DT line and check the COG, balance was good straight of the board. So all good and finished weight at 264grams.

Now it will sit on the modelling bench waiting patiently for the COVID19 restrictions to be lifted so that we can return to the flying field.

Stay safe and get to work on some of those projects on your list, so you can enjoy flying your models on the other side of the current social distancing.

Thank you to Pete Somers for the design and Kim Parks for circulating it.

Graeme Cooke  
WAMAC / SAM270

P.S. Also attached picture of our Beverley flying site.



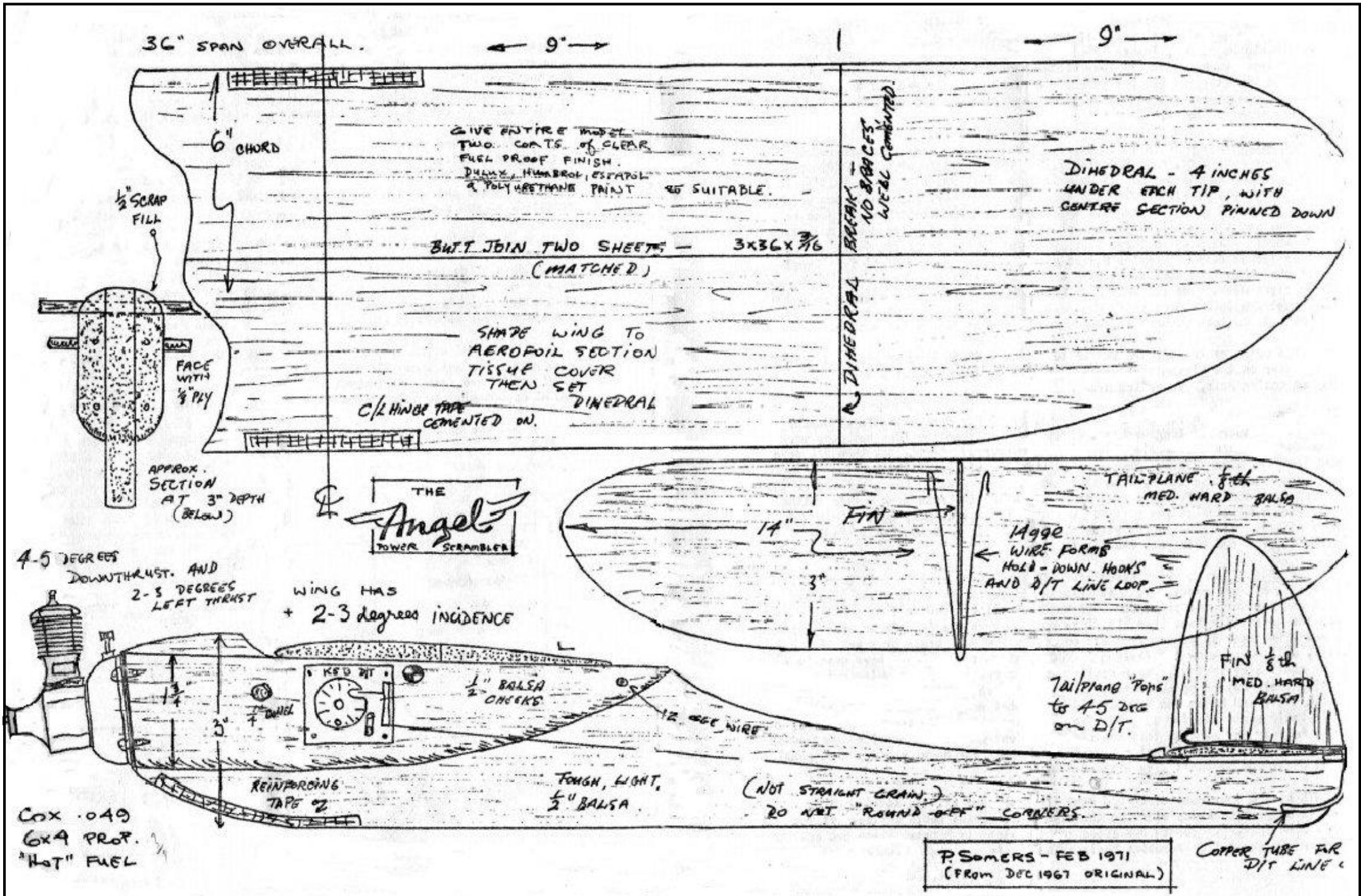







SAM 270 Flying Field at Beverley, W.A.

## TEXAN

By Hans van Leeuwen

Some time ago I decided that I needed to build a new Burford category model. I've built and flown a Lucky Lindy for some considerable time and have used the airframe for Burford, it's principle usage, for 2cc with an MVVS 2cc Junior as motive power and as a Nostalgia model with a Supertigre G15 on board.

The Lucky Lindy flies very well and my initial criterion was that I wanted a model that resembled an FAI power model, hence my choice of the Lucky Lindy.

The downside of the Lucky Lindy is its under-fins. Even with rudders on the under-fins the model lacks rudder authority at low speed when spot landing.

Once again I was on the hunt for a model that resembled a power model of the era as FAI power and its derivatives have always been my first love. After much deliberation and consultation with my old modelling friend, Fred Tower, we decided that the Texan would fill the bill. This model was chosen by the NFFS as one of its ten models of the year some time ago.

Both Lucky Lindy and Texan have undergone significant improvement changes over time, sadly these can't be incorporated into our Burford or Nostalgia models because of the end 1956 cut-off date. I've noticed that the Americans have set up a class called Golden Age for model from 1/1/57 to 31/12/69. That would allow those mods for those models. However, in the current climate we probably already have too many categories and adding to that will dilute the soup even more.

Fred arranged for a couple of Klarich short kits, bad mistake as it turned out, and I started building about 12 months ago. Because of its fuselage construction it was quite difficult to house the servos inside the fuselage. This led me to have them surface mounted on the fuselage with the pull-pull wires outside the fuselage, somewhat crude but seems reasonably effective.

One of the other requirements I've incorporated into my last 4 models is that they can be broken down into reasonably flat packages that can be readily transported, particularly to the East Coast if required. This necessitates split wings and removable rudders. Over time I've developed systems that are reasonably easy to build, locate the tail surfaces accurately and are relatively light. Thus those ideas were incorporated from the start.

I've also developed a cassette style of engine and fuel tank mounting system that allows for engine, mounts and fuel tank to be removed and replaced reasonably readily. This system also allows for the landing gear to be removed, again in an effort to reduce bulk for transport. Again that was incorporated into the construction process.

### Construction:

Unfortunately I did not take as many pictures as I should have during construction, but the things that are probably unique to my approach are on record. I'm also not the best photographer, but it will have to do.

### Wing:

The wing has pretty standard construction with provision for dismantling the wing at the centre section.

The system that I currently use incorporates carbon fibre wing joiners courtesy of my friend Fred Tower, who is my carbon fibre and glass fibre expert. I substitute 1/16" or 1.5mm good quality ply centre ribs in which I stack mill slots for the carbon joiners. I also make slotted hardwood rails to fit between the ribs to guide the wing joiners and give some extra strength to the joiner box. These rails are  $\frac{1}{4}$ " square hardwood and the slots are made on the mill. This seems to work quite well and is light compared with metal rods and brass tube or even carbon rod and carbon or brass tubes.

The benefit of tubes or rods is that they only require round holes and can thus be stack drilled. The carbon joiners can be quite thin because they give strength in the appropriate direc-

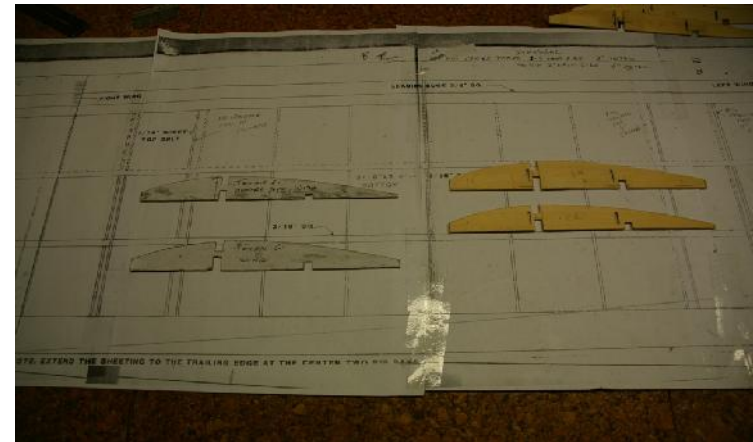

*Note slots in ply ribs*



*Wing joiners installed into ribs.*



*Shows bottom rails epoxied in place.*



Showing wing joiners and slots of finished wing.



Showing the wing joined.

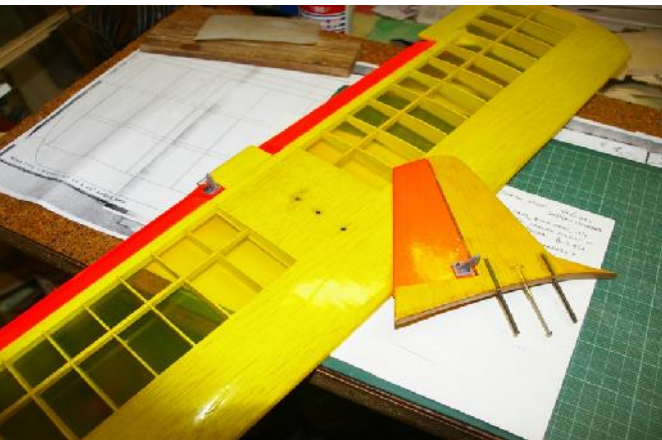

Carbon rods and fastening bolt for fin and tailplane.

tion and also do not twist as round material tends to do. Top rails are added and the centre section sheet covered, provision for the sheet covering was made prior. The rest of the wing construction is fairly orthodox and straight forward.

**Tailplane and rudder:**

Construction is fairly orthodox and straight forward. Provision has been made to bolt the tailplane, rudder and fuselage together with a single 2mm bolt. Alignment and rigidity are taken care of by a pair of carbon fibre rods and aluminium tubes. Most of that detail is shown in the pictures.

**Fuselage:**

This is a fairly standard box fuselage with good pylon strength. Cassette mounting of engine, fuel tank and landing leg are shown. That is the deviation from the plan that



Locating tubes & fastening bolt tube in tailplane mount.

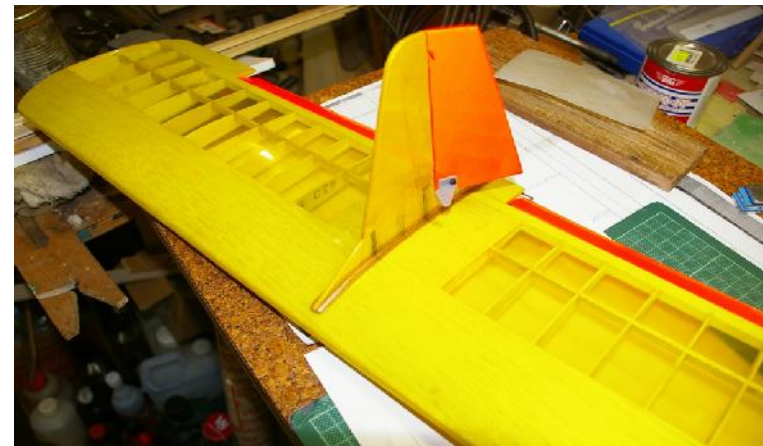

Showing rudder located into tailplane sockets



Showing tailplane and rudder assembled to fuselage.



Fuel tank with flanges, firewall, landing leg & engine mount at top.

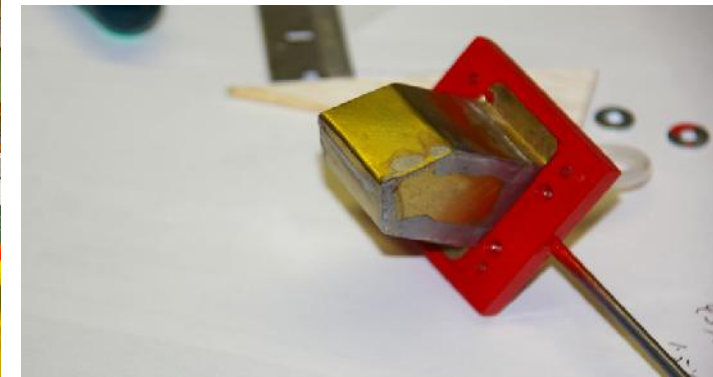

Tank fitted to firewall by pipes and recess in firewall.

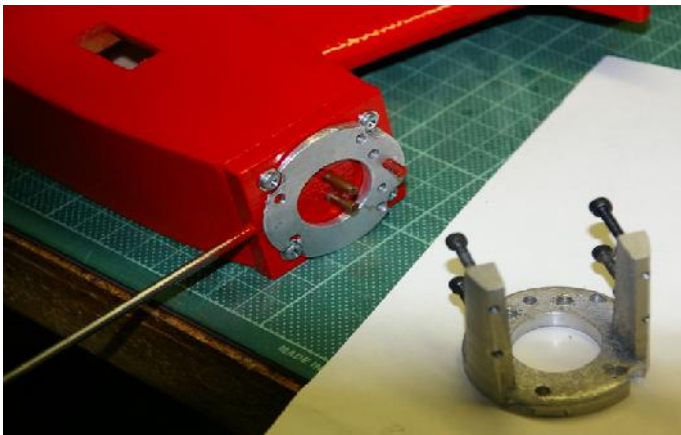

Firewall attached to fuselage, down-thrust plate and engine mount.

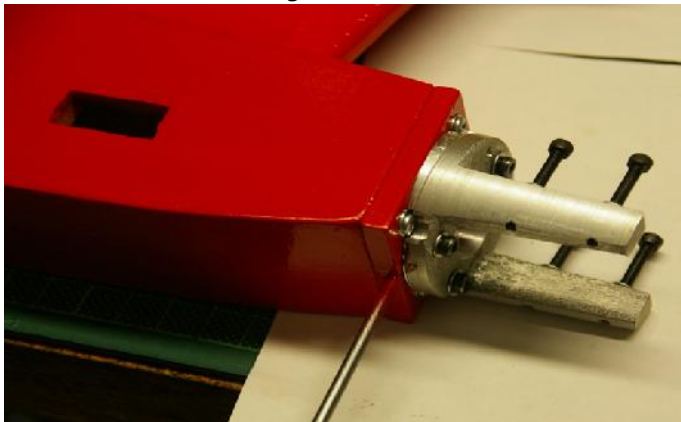

Engine mount fitted to firewall.



All set up for Burford.



I tend to make to all my models. It allows for complete engine and engine mount changes as well as access to the fuel tank and the removal of the landing leg for transport. Most of this is self-explanatory.

I will conclude with some pictures of the finished model. Sadly it has not yet been flown because of the current restrictive circumstances that prohibit us from crossing boundaries to places like our flying field.

Final pictures by courtesy of Fred Tower. I sincerely hope that it flies as good as it looks.

Regards, Hans.

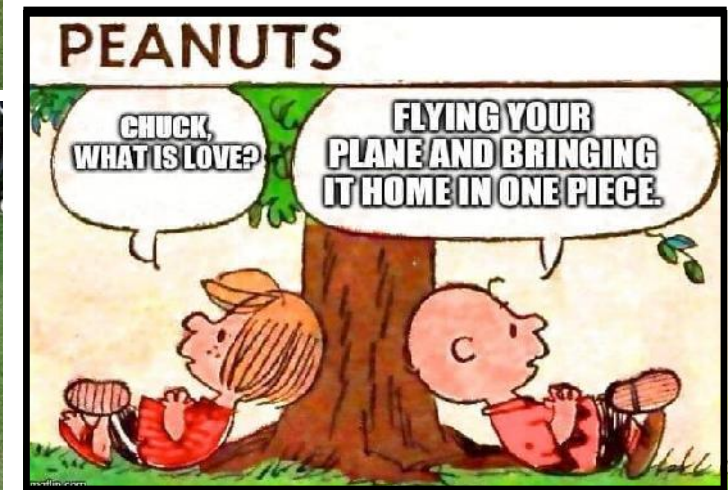

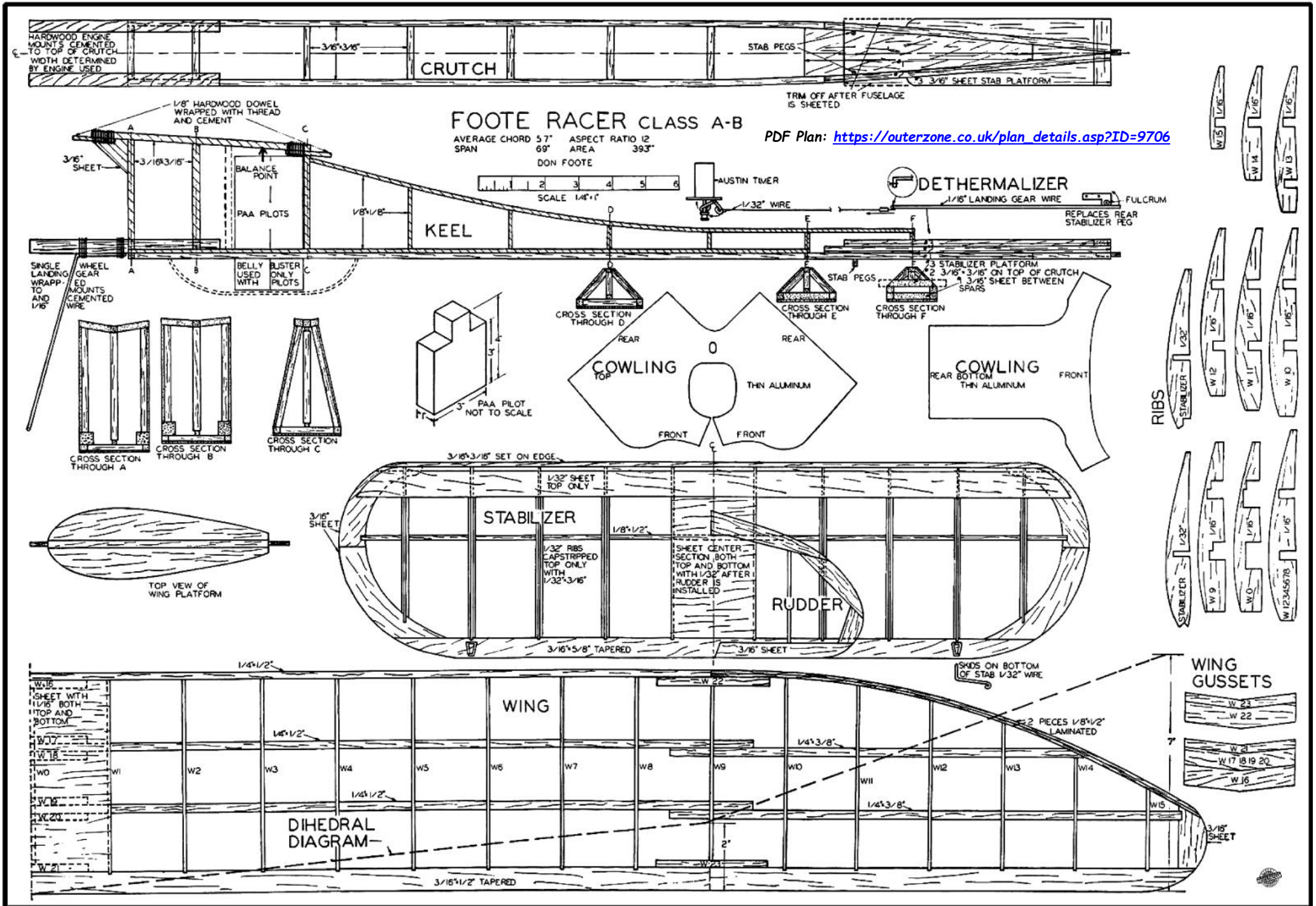

# FOOTE RACER

by DON FOOTE

**T**HE Foote Racer is not a new airplane. It is the final version of a ship that has been developing since 1942. In previous versions it has won many contests throughout the State of California; it missed taking first place in Class B at the big State Championships at Fresno in one year by 3 secs. The following year the same ship took first place in Class B at the same contest with the highest time for all classes.

It has been built and flown by a large number of modelers to test its reliability and stability. All have agreed that it is one of the most stable and best-performing ships they have ever flown.

The ship has been flown with almost every Class A and Class B engine on the market. Weighing in at 20 oz., with a Class A

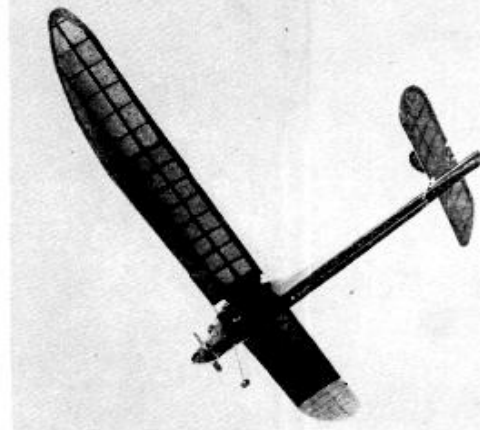

where a medium grade should be used.

The crutch is built first and is constructed flat on a board. The maple engine mounts are cemented in place on top of the crutch. A piece of 3/16" sheet is cut to fit between the spars at the tail. See #1 in crutch, keel, (or side view) and cross section through F.

The crutch is further strengthened at the tail by two pieces of 3/16" x 3/16" laid on top of the crutch spars. This is shown as #2 on the plans.

A piece of 3/16" sheet, (#3 on the plans), is cemented on top of #2 to form the platform for the stabilizer. Notice that the grain of this piece runs parallel to the crutch except at the very tail, where an additional piece is set in with the grain running cross-wise. Notice too, that the stabilizer platform runs into the fuselage beyond the point where the front of the stabilizer will rest, strengthening this usually weak point. After the fuselage is planked, the protruding part of this platform will be trimmed off.

The shaded portion, only, of the keel is built next. The hardwood dowel wing pegs are wrapped with thread and cemented in place before the piece of 3/16" that they are fastened to is cemented in place.

After the keel has dried thoroughly, it is removed from the board and cemented in an upright position along the center line of the crutch which is still pinned down to the board. The two pieces which form the wing platform are cut to shape and cemented in place at the slightly V'd angle shown in cross sections A, B, and C, so that they will fit the wing dihedral. The uprights which form the rectangular shape of the cabin and triangular shape of the boom are cemented into place. Notice that these pieces are set in 1/16" at the cabin and at the lower end of the triangular boom, but they are flush with the top of the keel. This is to allow for the 1/16" sheet with which the sides are covered. Although it is possible to cover each side with a single wide plank, it is easier to use a piece of two-inch stock the full length, then cut another piece to fit the remaining gap. The fuselage is left pinned securely to the board until after it is planked and the cement is dried in order to insure a straight fuselage. After it is removed from the board, the bottom is planked.

The protruding part of the stabilizer platform is trimmed off, and the fuselage sanded smooth, then covered with paper. The stabilizer pegs are cemented into holes drilled in the positions shown. The front pegs are on the bottom of the fuselage and are placed so that if a dethermalizer is used, no springs or hinges are necessary.

It is the greatest of folly not to use a dethermalizer on the Racer. The dethermalizer shown in the plans is designed to fit along the bottom of the ship and provides for an advantageous leverage to take the strain off the Austia timer. The 1/16" landing gear wire takes the place of the rear stabilizer peg. It is fastened to the bottom of the ship by two pieces of aluminum sheet which form a fulcrum. The tie-down rubbers are fastened from one of the forward pegs, over the stabilizer, around the wire, and back over the stabilizer on the other side of the rudder to the other forward peg. When the dethermalizer is

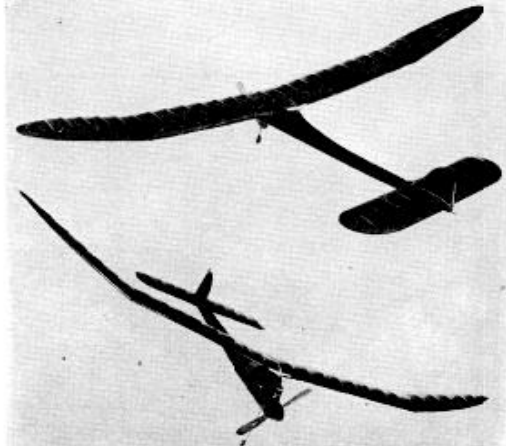

engine in its nose, the Racer is a floater beyond comparison. Because of its clean lines, the climb is still as good as that of most of the smaller Class A ships.

With larger engines, the ship becomes a racing skyrocket. Yet its super stability characteristics will roll it out of loops and spiral dives at a truly breath-taking speed. Although faster in the glide when loaded down with additional weight, its aspect ratio of 12 still insures a float beyond comparison, and it once won a Class B event at a weight of 36 oz., flying against lightly constructed ships where no weight rule was in force. This makes it an exceptionally capable airplane for the PAA-Load event, and space can be provided for a pilot for entering this event, as will be explained later.

A pop-up dethermalizer is shown on the plans and is strongly recommended to prevent lost ships. A new construction idea for the stabilizer platform strengthens the boom where most ships have a weak point.

Ignition can be installed in the space forward of the PAA-Load pilot compartment, but spark ignition is not recommended, especially in Class A ships, because of the additional weight.

Care should be used in selecting the wood. All 3/16" sheet should be soft. Spars should be fairly hard stock, and 1/16" sheet and 1/32" sheet should be medium. When building for the larger engines, harder wood should be used all the way through, and especially in spars. When building for smaller engines, soft wood can be used for all purposes except for spars,

INTRODUCING "SPITFIRE'S" LATEST and FINEST

**"Spitzy" .045 DISP.**  
Another "SPITFIRE" Product  
**More POWER than any Engine its Size**  
**America's Volume Engine Manufacturer's Answer To Your Demands**

**COMBINATION PACKAGE**  
• ENGINE • FUEL TANK • GLOW PLUG  
• COMBINATION CLIP • PROPELLER  
• PROP WRENCH • MOUNT BOLTS

**MEL ANDERSON Manufacturing Co.**  
1819 THIRD AVE., LOS ANGELES 6, CALIF.

Regular ANDERSON Quality

**ALL FOR ONLY \$3.95**

**THE BEST ENGINE YOU CAN BUY**  
**DYNA-JET**  
THE SUPER ENGINE

**THE DYNA-JET RED HEAD**  
FAMOUS JET MINIATURE GASOLINE ENGINE

**POPULARITY PROVED!**  
THE HIT OF THE 1948 CONTESTS

**OFFICIALLY ACCEPTED!**  
AMA RECORD 179.03 M.P.H.

**WORLD'S MOST ECONOMICAL!**  
WILL NOT WEAR OUT

**AEROMARINE COMPANY**  
Dayton Municipal Apt., Vandellia, Ohio

**SPEED!** 179.03 mph official AMA World Record! Guaranteed to develop over 4 1/4 lb. Static Thrust, the equivalent of more than 2 Hp, exerted at 125 mph with 70% propeller efficiency! **COMPACT!** Maximum diameter is only 2 1/2", overall length 2 1/4", and weighs only 16 ounces! **SPORT!** The easiest starting and most reliable engine ever built. No propellers to break. No ignition system to burden your model... no fuel to mix... runs best on plain gasoline without oil! **GUARANTEED!** 1. To start easily with hand tire pump. 2. To equal or exceed advertised power. 3. Against defective material or workmanship. **\$35.00!** At your dealer's. If he can't supply, order direct. Immediate delivery! **MODEL AIRPLANE KIT!** For Dyna-Jet, by leading mfgs., at your dealer's. Not sold by Aeromarine Co.

The more people SEE Dyna-Jet in action the more people BUY Dyna-Jet. Two years on the market and today more popular than ever. The center of attraction wherever it is used!

Officially accepted by AMA for all contests and as holder of the world speed record. Accepted by Airplane Kit builders. Owner acceptance... Just ask the man who owns one!

No propellers to break... no bearings or pistons to wear out. Constant high re-sale value! Savings can more than make up the difference in cost between Dyna-Jet and cheaper engines in only one season's flying! Your most economical buy!

## Foote Racer

released, the wire hinges upwards at the rear allowing the rubber bands to fly off the wire and come to rest around the rudder, causing the stabilizer to pop-up at the rear. A string is used as a stop to limit the angle of pop-up; 40° is recommended as a starter. Too fast a rate of descent will result from too large an angle of pop-up, while a spin will result from too small an angle.

The rudder is next built flat on the plans, and after thorough drying, is removed so that the stabilizer can be built.

In building the stabilizer, note that the ribs are cut from 1/32" sheet. Be sure that the spar is raised from the board slightly so that it is flush with the bottom of the ribs. The 1/32" sheet over the front of the stabilizer does not come clear to the tips so that the spar is raised from the board slightly so that it is flush with the bottom of the ribs. The rudder is removed from the board. The rudder is cemented into place, the front of the stabilizer and the center section are sheeted, and to guard against warps, the cap strips are put on the ribs before the stabilizer is removed from the board.

After the cement is dry and the stabilizer has been removed from the board, the lower part of the center section is sheeted. The front and ribs are not sheeted on the under side. Trim, sand, and cover with paper. Finish with four coats of dope.

The two 1/32" wire skids are cemented into place after the stabilizer is completely finished. These weak skids are far more practical than sub-rudders, for they will bend when hit from the side, whereas a sub-rudder will break or pull out.

From the center of the wing to the outer dihedral joint, the leading edge is made from one piece of balsa. Beyond this, it is laminated from two pieces. A single piece can be used here also, but it is not recommended because it puts a strain on the wing which might cause warps. The first piece of the laminated leading edge is cemented to the ribs. The second piece is not cemented to the first until the cement holding the first piece is dry; then it is cemented to the first piece and held in place with spring-type clothes pins.

All dihedral joints should be put in at once. Pin the center section to the board; then block up each outer dihedral joint and the tips the proper amount. Therefore, a jig is formed which is necessary to control warps and should be used when doping the wing, as explained below under flying instructions. Waxed paper can be used under each joint to prevent the wing from sticking.

The cowling should be made from thin aluminum sheet, although the metal from an old tin can will do.

The PAA-Load event rules for 1950 specify that the pilot must face the front of the plane. This amounts to requiring a minimum cross section for the ship in addition to requiring the ship to lift a load. It is a tremendous advantage in streamlining to use a minimum cross section. In ordinary AMA contests, no minimum cross section is required. Therefore, if the flier does not intend to enter his Racer in a PAA-Load event, it is recommended that a narrow fuselage as shown on the plans be used.

If the ship is to be used for the PAA-Load event, the fuselage must be widened out so as to provide enough space for the pilot. This is done simply by building the crutch wide enough so that it will accommodate a three-inch wide pilot. The crutch should be tapered as rapidly as possible behind the point where the pilot is to be placed.

The wing platform must also be widened out to accommodate the three-inch pilot. In this case, the rear of the platform is left square instead of being cut to a streamlined shape.

The front section of the keel is built just as on the plans from the point of cross section C forward. From cross section C to the rear, two identical keels are built, one on top of the other.

The front portion of the keel is cemented to the center line of the crutch as before and the wing platform is built up from the two keels from cross section C rearward are cemented along the outer edge of each

# New HOT-POINT Glo-plug

Weight 1/12 oz. Length overall 1/2"  
Length above head 1/16"  
Body 1/16" hex 1/4 - 28 Thread  
Special Iridium Platinum Element



Ed Sharp holder of Class B, C and D World Speed Records, until forced by company policy to withdraw from competition when he entered the employ of Duro-Matic Products Company as assembly superintendent, says—"I sure wish that the new 1950 HOT-POINT Glo-plug was available to me when I was flying speed! My testing shows that it is at least 1,000 RPM faster than any other plug that I have tested. They last so much longer, that I know I would never have ignition troubles with the new HOT-POINT Glo-plug!"



New low price of only . . . **49c**  
AT YOUR HOBBY DEALERS

**DURO-MATIC PRODUCTS COMPANY**  
HOLLYWOOD 38, CALIFORNIA

crutch spar to form the sides of a rectangular fuselage. Cross members are inserted across the top of these two sides; the top of the fuselage is planked as well as the sides. Uprights within the cabin are used to keep the pilot in place. These are shown on the plans as dotted lines just behind the upright at cross section B. When a Class B motor is used, two pilots are used. The plans show the two pilots in place. If a Class A motor is used, only one pilot is necessary. In such a case, the upright is placed farther back so the pilot fits snugly in the body. The pilot, or pilots, should be placed so that they come directly under the center of gravity so as not to change it when they are in place.

The belly blister is also necessary when using the PAA-Load pilots. If the ship is built so that it can house a pilot, it can also be used in regular AMA contests by simply removing the pilot and replacing the belly blister with a flat door. The drag from the greater cross sectional area will reduce the performance somewhat, but it will save the contestant the job of building two ships.

The PAA-Load rules for 150 also require that the pilot have a view both to the sides and to the front. It is therefore necessary to cut a window on each side of at least one-inch square and to provide an adequate opening in the front for a windshield. These can be covered with thick cellophane without reducing the strength of the cabin.

I have found the following method of adjustment allows for the greatest necessary on the part of the flier, and I recommend its use on the *Racer*.

First, be sure that the ship balances perfectly level when held at the balance point. Suspend it from a string to be sure. Then, add pieces of 1/16" sheet under the leading edge or the trailing edge of the wing until the longest, flattest glide is obtained. You will probably have to add weight to the nose to make it balance correctly, and more than likely you will have to add blocks to the rear of the wing to obtain the best glide. The wing and stabilizer should be keyed in position to insure that the ship will fly the same way on each flight. Small pieces of 3/16" square cemented to those members at their four corners is the simplest way to key them in place.

The following adjustments are for a left turn in the climb. If a right turn is desired, all the adjustments must be reversed. If only one or two are changed, without changing all the others, there is danger of a crack-up.

When doping the wing, pin it into the jig used for putting in the dihedral. Eliminate the outer blocks and use only the blocks under the dihedral joints. Place an additional 3/16" block under the leading edge of the left wing at the outer dihedral joint. The center dihedral joint and the outer dihedral joint of the right wing must remain flat. This gives the left panel a slight warp and it will have 3/16" more incidence at the dihedral joint. The drag caused by the warp in the left wing will cause the ship to turn to the left in the glide. The greater the warp, the tighter will be the turn. A smaller warp will result in a larger circle in the glide. Be very careful to pin

the wing down securely after each coat of dope and allow it to remain in the jig overnight after the last coat of dope. This is the only adjustment for putting in turn in the glide. The stabilizer should be absolutely flat, although a warp one way or the other can be overcome by warps in the wing if it is not too great.

Partially counteracting this turn should be a slight amount of right rudder. This is put in when the rudder is being cemented to the stabilizer. The entire trailing edge of the rudder is broken loose and re-cemented onto the stabilizer so that it has about 3/16" right offset. The rudder should not be moved later under any circumstances.

The ship should be made to climb in the same direction as it glides. To do this, it is necessary to make the one adjustment that will not affect the glide. That is, give the engine side-thrust. Start with the engine pointing straight ahead. As more and more power is added, it will be found that the left turn in the climb will tend to straighten out due to the warp in the left wing panel lifting at higher speeds. As higher speeds are attained in the climb, more and more left-thrust will have to be added. If the ship starts to turn to the right at high speed when adjusted with a warp in the left wing, it will spiral dive, but it will pull out of a left spin even though the circle is extremely tight. So, it is better to have slightly too much left-thrust than not enough. Once the ship is adjusted for high speed it should never be flown at reduced throttle.

By Ron Warring

# The Foote Racer

DON FOOTE, noted Californian free-flight power modeller, is best known for his *Westerner* series of designs. Although a pylon layout, the *Westerner* featured a high aspect ratio wing of characteristic planform. The outer panels had a curved taper on the leading edge only, a feature which Foote has retained on all his subsequent published models. Planform, and construction, of his latest—the *Racer*—is still almost the same as that of the original *Westerner*, with a few detail improvements.

The *Westerner* was, in many respects, an ugly machine. The same can be said of the *Racer*. In fact, in appearance, this new design differs only in having the fuselage cut off along the datum line for a flat, straight undersurface. The *Westerner* featured a deep belly fairing, sweeping back and up into the lines of the main fuselage.

It is evident, too, that the same basic methods of construction has been retained which, presumably, is adequate proof of its suitability. To British eyes, at least, it appears to be a trifle on the weak side, relying almost implicitly on the sheet covering to give adequate strength and rigidity.

We had our first experience of flying with a *Westerner* some two years ago. This was the smallest version, powered with a Frog "100." Performance was every bit as good as could be expected of any Class "A" model, once a few of the initial bugs had been trimmed out. The glide in particular was really excellent, and climb was rapid in a left hand spiral. Considering that this size of *Westerner* was designed to take motors up to 3.25 c.c. capacity (American '19's'), climb with a larger motor would have been sensational—if it could have been controlled. Our own opinion was that anything over about 2 c.c. capacity would have made the design too "hot" to handle with comfort, especially a spark-ignition motor with its attendant extra weight.

The *Westerner* was definitely not happy turning to the right under power. Any degree of right turn under power, in fact, was asking for a spiral dive. This was one of the initial troubles experienced which was eventually tracked down to a wash-in warp on the port side of the tailplane. Structurally we found the tailplane very poor as regards warping. Two or three tails made off the same plan all exhibited warps, and no two exactly the same. Monospar construction on a parallel chord, low aspect ratio aerofoil does suffer from this inherent fault.

The high aspect ratio wings were more than strong enough with the ample spar sizes recommended and their only fault was that their large span made them difficult to transport. Class "C" *Westerner* wings in one piece, for example, were almost impossible to get inside a car. For this reason alone this particular model was not taken out and flown much, but the flights that it did make showed it to have very similar characteristics to its smaller brother, with an even better glide, but more moderate climb (Ohlsson 60).

For general flying the smaller *Westerner* fuselage did not prove strong enough. One spiral into the ground snapped the fuselage in half just aft of the wing mount. When one bears in mind that the plans of the Class "C" *Westerner* showed the same size longerons—only 1/4 in. sq. balsa—the durability of this fuselage was more than suspect. But we were sufficiently impressed with the flight performance to look upon the design as something decidedly better than the average.

Foote's next published design was a shoulder wing model, again with that characteristic wing planform. We have not seen any examples flying in this country and have no record of it doing anything sensational in America. The fact that it was a shoulder wing type with little or no downthrust and the c.g. rigged well aft almost certainly means that it was decidedly tricky to trim and fly. We are not surprised, therefore, that the *Racer* reverts to more or less the original layout.

The *Racer* is typical of the modern trend to reduce pylon height. There should actually be an optimum pylon height for any particular size of model and motor, but the only way to arrive at this is by trial and error methods, at present.

The fuselage itself is very simple, reasonably strong and aerodynamically good on account of its very slim lines, although the actual entry of the front of the pylon would appear to leave much to be desired. The plans are not clear on this point. The front former offers a flat plate section, with a triangular gusset



MODEL AIRPLANE NEWS • September, 1950

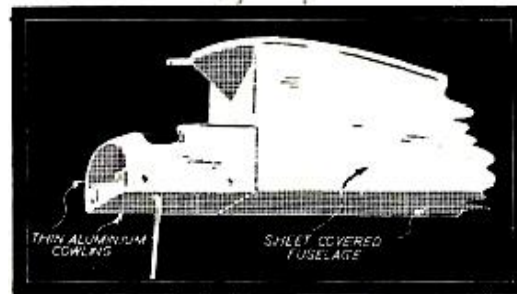



January 1951

projecting from it up to the wing platform. Just how the covering fares in this abrupt change of section is problematical. But this time a definite cowling has been produced for the motor, this made of thin aluminium or tinplate. Tinplate, incidentally, is not to be ignored as an easily-worked metal cowling material. Some examples have given excellent service on control line models over a period of a couple of years.

The motor is beam mounted, as on the original *Westerner* (which left the motor simply sticking out in front) and the undercarriage legs bound to the bearers in the absence of any ply former. This again appears to be satisfactory. But in spite of the ingenious construction we cannot credit the fuselage with enough strength to resist a crash landing. Main members have been increased in size to  $\frac{3}{16}$  in. sq. and the whole fuselage sheet covered as before. The tail area is strengthened by "layer" construction, the sheet tailplane platform forming the top layer. This undoubtedly strengthens the possible weak point on the fuselage by the tailplane leading edge, but now transfers this farther forward to where there is a marked change in section between the end of the first layer and the crutch proper.

Wing construction is only slightly modified from that of the original *Westerner*. The curved outer panel leading edge is now made from two pieces of  $\frac{1}{2}$  in.  $\times$   $\frac{1}{8}$  in. balsa in the form of vertical laminations—a very effective method indeed of making curved edge spars. Spars at the dihedral breaks have been lap jointed, again effective and avoiding the use of spar strengtheners at these points. Normal sheet balsa spar joiners (or dihedral keepers) are employed at the centre section joint, and at leading and trailing edges at the outboard dihedral breaks. All spars of generous sizes, the two mainspars being

MODEL AIRCRAFT

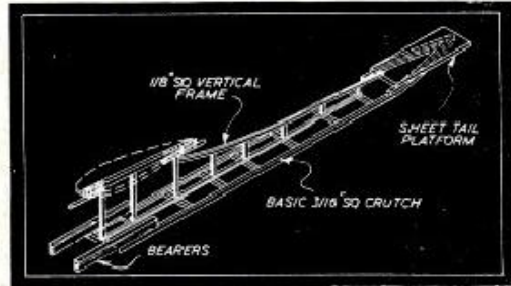

$\frac{1}{2}$  in.  $\times$   $\frac{1}{8}$  in. and the leading edge the same. The trailing edge is  $\frac{1}{2}$  in.  $\times$   $\frac{3}{16}$  in. stock.

The tailplane structure employs  $1/32$  in. thick ribs—unusual on so large a size—but these are capped with  $\frac{3}{16}$  in.  $\times$   $1/32$  in. strips, serving the dual purpose of giving the thin ribs rigidity and bringing them up to the level of the  $1/32$  in. leading edge capping. The leading edge proper is  $\frac{3}{16}$  in. sq., set diagonally.

It would appear that the tailplane is still not fully warp-resistant and that an asymmetric twist may develop unless pinned down after water spraying and doping. The leading edge will be rigid enough with its sheet capping, but the trailing edge is still relatively free to twist. Our own attempts to build a non-warp tailplane of similar planform utilised a built-up trailing edge with sheeting extended on the top surface some 1 in. forward. This definitely adds the rigidity required, although at the expense of a certain increase in weight.

Weight distribution on the *Racer* can be critical. Total weight is not so important. Wing area quoted by designer Foote on the reduced scale plan as

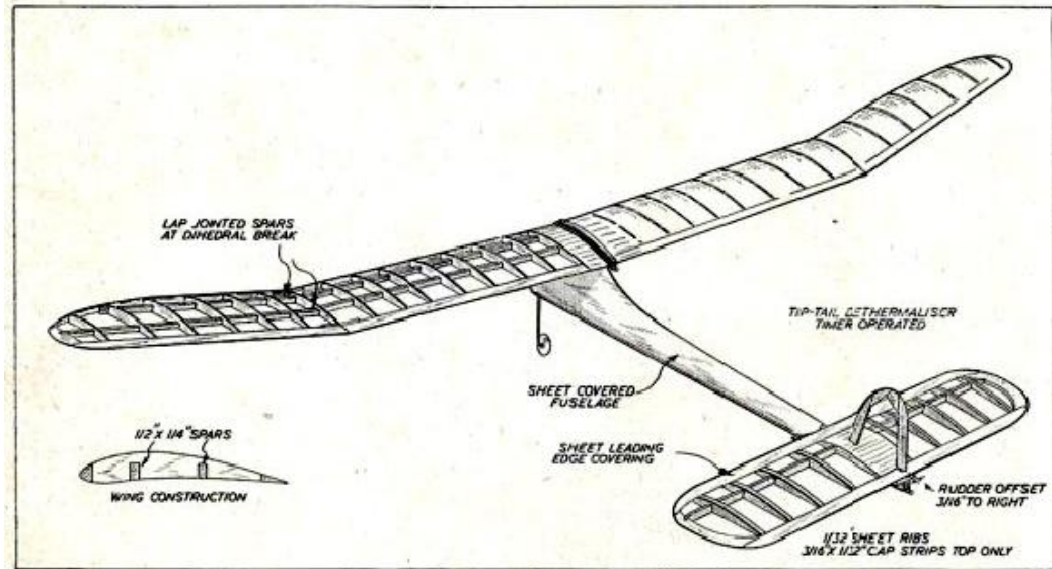

MODEL AIRCRAFT

originally published is 393 sq. in., whereas in actual fact laid out to true dimensions the area is almost exactly 430 sq. in. Working on the assumption that for a model of this size a wing loading of not more than 6 oz. per 100 sq. in. is necessary for true "duration" performance, total weight of the model can be as much as 25.8 oz. Various all-up weights are quoted for the *Racer*, 20 oz. with a Class "A" motor and 36 oz. with a Class "B" motor being typical. These correspond to loadings of 4.65 oz. per 100 sq. in. and 8.4 oz. per 100 sq. in., respectively.

The *Racer* is essentially a Class "A" design (American Class "A," with maximum motor capacity 3.25 c.c.), and with a designer's weight figure of 20 oz. for these motors should be readily duplicated within the 25.8 oz. desirable maximum.

Where weight is likely to be critical is in affecting balance. The type of construction used, with fuselage sheeting, is going to bring the centre of gravity of the finished fuselage alone fairly well aft. The motor is mounted just in front of (and below) the leading edge of the wing and some difficulty may be found in achieving the design c.g. position (75 per cent. chord) without some additional nose ballast. The fuselage tail end, and the whole tail unit, will have to be kept as light as possible.

Size of the model should be very well suited to a good American "19" motor, glow-plugged to eliminate the weight of ignition components, and built to an all-up weight not exceeding 25 oz. Climb with such power should be as fast as necessary for any open power-duration competition and glide will be excellent on account of the moderate loading. Further reduction in weight will give even better climb and glide performance.

With a larger motor, the *Racer*, we are sure, will tend to be tricky to trim out. It does not need any more power than a good "19" to have a really first class performance. Using a larger and heavier motor will give increased rate of climb at the expense of a more difficult model to handle, and decreased glide performance on account of the higher loading.

For British competition work, however, the *Racer* would appear to be an almost ideal two-class machine. Any of the good 2.5 c.c. British diesels (Elfin, Mills,

E.D.) should give it a performance comparable with that of an American "19" to qualify for (British) Class "A" (motors up to 2.5 c.c. capacity). Any good "19" (3.25 c.c.) could be used to make the *Racer* a (British) Class "B" contest job (motors 2.51 to 5 c.c.).

Trimming technique adopted with the *Racer* is typical of the modern way of handling pylon designs with moderate pylon heights. This is to make the model turn left under power—never right—against a slight amount of right rudder offset. This, of course, needs left sidethrust, erring on the side of too much, rather than too little motor offset.

Foote also uses wing warping in conjunction with offset thrust and right rudder to achieve trim. Wash-in is given to the port wing, so that this wing will drag on the glide and give a left hand glide circle—this against the action of rudder. Under power this warp will tend to roll the model around to the right which, together with the rudder offset, has to be overcome by sidethrust. Thus the safety of the trim relies very much on the action of sidethrust. For a right turn under power is almost certain to lead to a spiral dive.

Whether this type of trim is the best to use or not is open to doubt. The use of wing warping, now frequently employed, can lead to trouble unless the action of these warps is properly appreciated. The use of opposing forces, however—e.g. thrust offset against rudder—is generally recognised as desirable.

Strangely enough, on some high pylon designs, increasing the amount of left sidethrust can often make the model turn even more strongly to the right. On high pylon models there is a definite tendency to turn right under power, almost certainly the result of slipstream action on the pylon itself. The slipstream, rotating anti-clockwise as viewed from the front, imparts a side force on the pylon tending to roll the nose of the machine around to the right. A high pylon, therefore, can render sidethrust relatively ineffective. Hence the potential advantages of moderate pylon height.

Not so many years ago it used to be the accepted practice to let pylon models turn in their "natural" direction—i.e., to the right, usually with a small

January 1951

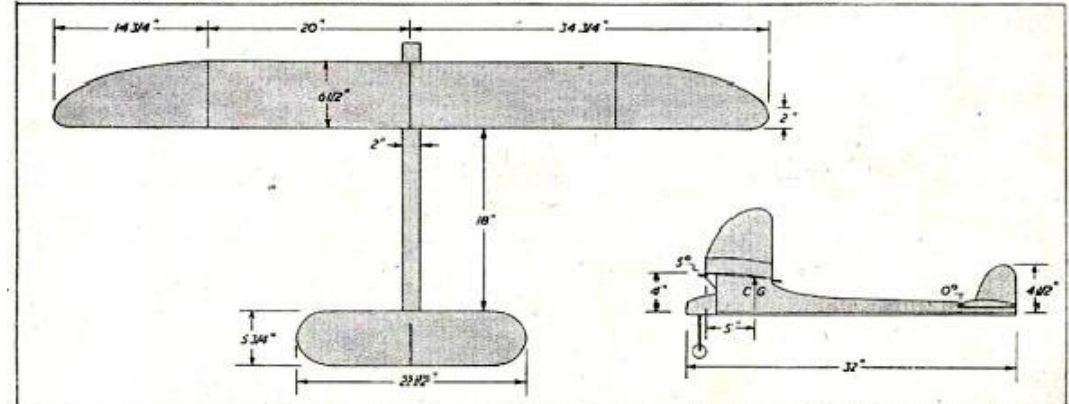

January 1951

amount of left rudder offset. Glide circle was opposite to climb circle. A left climbing turn is now recognised to be safer, achieved with sidethrust, the nose of the model having a natural tendency to come up due to gyroscopic action and thus lessen the risk of a spiral dive. At the same time, many designers feel that opposite rudder is still very necessary as an additional safeguard to keep the nose up. The only simple way to get a glide circle in the same direction then is to use wing warping or, rather better, trim tabs on the wings. Having the glide circle the same as the power-on circle enables the model to be trimmed out without that stall and dive following the motor cutting. Transition from power to glide should be smooth, especially for ratio duration contests. In the latter, without doubt, a consistent high average is best obtained by using the minimum possible motor run (10 sec.), when every foot of altitude helps in prolonging the glide. To lose a 100 ft. or so in a series of vicious stalls when the power cuts may halve the possible ratio on any one flight.

### About this Plan

Foote Racer. Free flight power model. Foote Racer, MAN September 1950.

Quote: "THE Foote Racer is not a new airplane. It is the final version of a ship that has been developing since 1942. In previous versions it has won many contests throughout the State of California; it missed taking first place in Class B at the big State Championships at Fresno in one year by 3 secs. The following year the same ship took first place in Class B at the same contest with the highest time for all classes. It has been built and flown by a large number of modellers to test its reliability and stability. All have agreed that it is one of the most stable and best-performing ships they have ever flown.

The ship has been flown with almost every Class A and Class B engine on the market. Weighing in at 20 oz., with a Class A engine in its nose, the Racer is a floater beyond comparison. Because of its clean lines, the climb is still as good as that of most of the smaller Class A ships. With larger engines, the ship becomes a racing skyrocket. Yet its super stability characteristics will roll it out of loops and spiral dives at a truly breathtaking speed. Although faster in the glide when loaded down with additional weight, its aspect ratio of 12 still

insures a float beyond comparison, and it once won a Class B event at a weight of 36oz, flying against lightly constructed ships where no weight rule was in force. This makes it an exceptionally capable airplane for the PAA-Load event, and space can be provided for a pilot for entering this event, as will be explained later.

A pop-up dethermalizer is shown on the plans and is strongly recommended to prevent lost ships. A new construction idea for the stabilizer platform strengthens the boom where most ships have a weak point. Ignition can be installed in the space forward of the PAA-Load pilot compartment, but spark ignition is not recommended, especially in Class A ships, because of the additional weight. Care should be used in selecting the wood. All 3/16in sheet should be soft. Spars should be fairly hard stock, and 1/16in sheet and 1/32in sheet should be medium. When building for the larger engines, harder wood should be used all the way through, and especially in spars..."

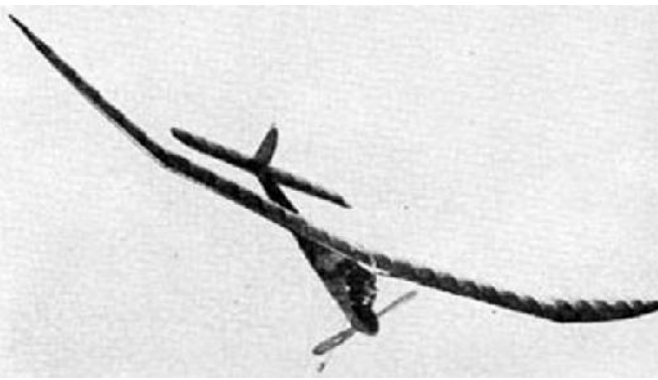

### MODEL AIRCRAFT

Trimming technique is still largely a matter of individual preference, but certain designs do definitely respond best to certain methods. The *Westerner* series, and the *Racer* represent a case in point where a left hand climbing circle is undoubtedly the only sound approach. One of the main points to remember with these or any other designs is that if wing warping is used, a power-on turn which may develop in the opposite direction to a wing with wash-in (i.e. a left hand turn in the case of a model with wash-in on the starboard wing, and vice versa) is almost bound to end up in a spiral dive. Also under power, wash-in on a wing gives more lift on that wing and a turn in the opposite direction. On the glide conditions are reversed. The wash-in produces greater drag on that wing and a turn in that direction. Where many less experienced modellers come unstuck is that under low power wash-in may have "glide condition" effect, changing over to the opposite action under high power. Thus a duration model trimmed out for stable flight under full power may be dangerous to fly under reduced power!

## From SAMTalk - Discussion on the Foote Racer.

\*\* Has anybody out there in SAM Talk land ever built and flown a Foote Racer? It shares a wing and general layout with the Foote Westerner. I've seen plenty of Westerners in SAM free flight and in SAM RC ships. I saw Ed Hamler putting up a maiden test flight on a Foote Westerner that one of his friends built. Ed's a good pilot, but that test flight at Eloy one year looked a bit "hairy".

The Racer is from 1950 so is now a SAM legal model. Maybe 30 years ago the SCAMPS were disposing of some of Bill Dean's old models and I acquired a Racer fuselage that had a glow .15 on the nose. At the time Bill might have intended it for Nostalgia Gas contests? It was just the fuselage and motor and I was more interested in some of the Delrin bits and pieces that Bill had machined to control fuel shutoff

But the Racer does have a nice 12:1 aspect ratio wing - and it apparently can be built to less than 20 ounces. With that wing it might make a nice Speed 400 ship - and if that didn't work out in practice, it would go up nicely with an Elfin 2.49 diesel. Ron Warring had a review of the ship in an old *Aeromodeller* and says the plan calls out 393 inches of wing area, but if you lay the wing out flat it's actually 430. That puts it right in the neighbourhood of the Fubars that Walt Angus and Jim Wiseman have been flying for Speed 400.

But back to my original question - if you've built and flown a Foote Racer, how did it work out for you?

Mike Myers mikemyersgin@charter.net

\*\* Anyone have a 3 view, plan, or photo we could view?

Bob Angel. samrcflier@verizon.net

\*\* I found one on Outerzone, Bob, and I'm working on the wing area now. There is a scale on the plan and it looks to me like the projected span is closer to 68 inches than 69. Here's a link to the plan.

[https://outerzone.co.uk/plan\\_details.asp?ID=9706](https://outerzone.co.uk/plan_details.asp?ID=9706)

John Eaton. jeaton01@gmail.com

\*\* John, Been here in quarantine time, I decided to make good use of extra spare time with your plan. Here, my best CAD approximation for Foote Racer wing dimensions. (See next page)

Alfredo Herbón herbonalfredo@fibertel.com.ar

\*\* Alfredo, I see you calculated aspect ratio from plan area, while I used projected area. 11.71 versus 11.11. I'm surprised it makes that much difference. my area is 422.5, where you got 423.4 Thickness of the lines must make that much difference.

John Eaton. jeaton01@gmail.com

\*\* Foote Racer plan can be downloaded on Outerzone - along with the original article by Done Foote and the article by Ron Warring. Frankly under power, from say a

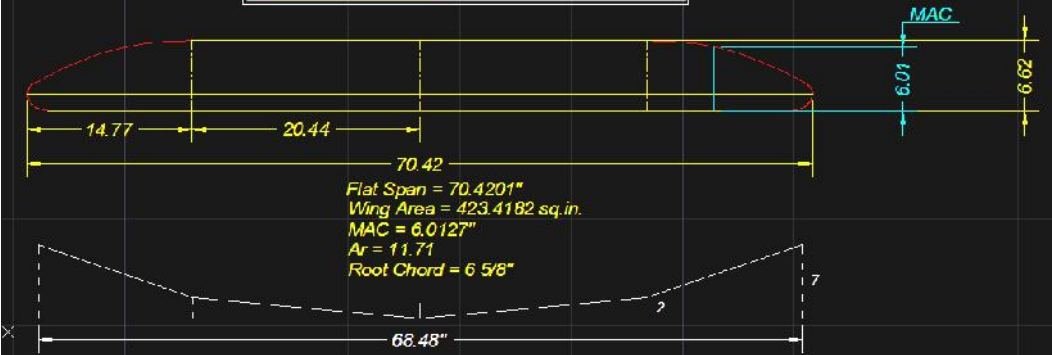
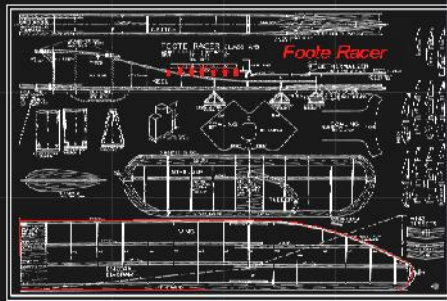

Here, my best CAD approximation for Foote Racer wing dimensions.  
 Alfredo Herbón herbonalfredo@fibertel.com.ar

healthy Glow .19, I don't think it would fly much different from a Foote Westerner. But I saw Ed Hamler having a "handful" on a Foote Westerner's first test flight at Eloy a few years back. That said, if I'm flying it with a Speed 400 motor, it's not going to be going up that fast.

And while we are playing with the wing area on the "ideal" Speed 400 ship, we have to consider the changes in the "legal" motor run. For most of the SAM contestants with increasing age and diminishing eyesight the original 3 minute motor run was not optimal. Many of the Speed 400 flyers couldn't see their model at the end of the legal motor run.

The 1/2 A RC Texaco boys mostly went for 288 square inch models (scaled from various designs) because they had an 8 ounces a square foot wing loading rule, and a 16 ounce model was optimum for what a Cox reed valve 049 could haul up.

Speed 400 rules however set a minimum weight of 16 ounces and no wing loading requirement. As long as you were going to have a 3 minute motor run, then having a larger model that was easier to see made sense. Almost any of the Ohlsson .19 or Ohlsson .23 designs had wing areas between 300 and 320 square inches, and they went up nicely on the Speed 400 motor. My Scientific Coronet had 300 square inches of wing area, and even ten years ago went O.O.S. on a 2 minute and 30 second motor run and I used to cut the motor at that point. Jim Wiseman pointed out that I could just reduce power and stooze around and get the 3 minute power run. Well people got "bigger" with their Speed 400 models. Hence the 375 square inch and

the 415 square inch Fubars that has been flown in Speed 400. Now, with the "legal" motor run cut down, you might not need to build those larger models for visibility. I'm still taken by the Foote Racer and will build one - although if it proves to be too big for the "new rules" Speed 400 event, I might have to re-motor it with a glow engine of some kind and fly it in Glow A. Mike Myers. mikemyersgin@charter.net

\*\* I get the plan area as 422.5 sq.inches, and the "ideal" projected span as 68 1/2 inches, but that could vary 1/2" either way, depending on the point you bend the wing when you put in the polyhedral. The airfoil looks a little thick to me, but I've always heard the Foote Westerners flew well. John Eaton. jeaton01@gmail.com

\*\* Mike, I get the aspect ratio as 11:1 on the racer. Nice! John. jeaton01@gmail.com

\*\* Well I also like to fly Dick Twomey's Leprechaun glider which has an aspect ratio under that. Mike Myers. mikemyersgin@charter.net

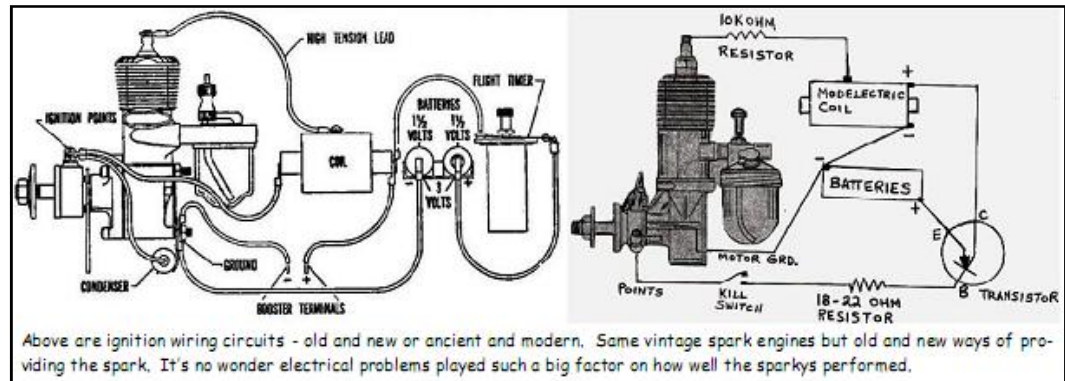

SAM 84 QUEENSLAND

**President:** Tony Hart  
**Phone:** 4923528  
**Email:** t.hart1946@gmail.com  
**Treasurer:** Ian Alexander  
**Phone:** 32028464  
**Email:** ial32263@bigpond.net.au  
**Secretary:** Mike Moore  
**Phone:** 4451740

No reports from SAM 84. Overleaf is an outline of the Sarina Aero Modellers club Old Timer Championships which has been held for the past 19 years. Their 20<sup>th</sup> Championships has had to be re-scheduled in 2020 due to the restrictions as a result of the Corona Virus. Let's hope their new plans are successful.



Inaugural winners at 2001 Sarina Old Timer Championships  
John Urry (left) and Warren Hatherway



Sarina CD Mike Rankin

## Sarina Aero Modellers matures into its 20<sup>th</sup> year of Old Timer Championships

From Mike Rankin

Photos and captions from Neville Parchert

Back in 1998 an inaugural meeting was held to form the Sarina Aero Modellers club and to provide a venue for model aircraft enthusiasts in Sarina Queensland. A couple for the founding members already had experience in travelling to old timer competitions and introduced this class of flying to the membership. It was decided that we should run our own annual competition to add to the annual round of events run by Rockhampton, Mackay and Townsville.

The invitation for the first Sarina Old Timer championship in 2001 was accepted with great enthusiasm by about a dozen participants. The weekend started with everybody setting up for Texaco Saturday morning and then the welcome speech by the CD and President. All competitors were surprised when the CD did not declare a start to the Texaco event but instead announced that we would be having coffee and sconces to get the day started.

This set the tone for all future events where competitors would be guaranteed a friendly and relaxing weekend, enjoying both the sport of competition and the company of fellow modellers. Onsite camping and full catering has been appreciated by the competitors over the years and is possibly a major part of the attraction to these events.

Sarina Aero Modellers is a small club of about seven regular active members who all band together and work hard to produce a two-day OT competition weekend which everybody should experience at least once in their modelling life.

John Urry was the proud recipient of Texaco 1<sup>st</sup> place in 2001. This is the main trophy event for the weekend and he has been followed by 18 more championship winners since that time, with Garry de Chatsel holding the record of four wins over the 19-year period.

Rockhampton aero modellers have been our strongest



Early morning camp at Sarina Texaco Champs. Part of our large camp site with donkey hot water system chuffing away,



The Sarina catering area. Marianne, Mike Rankin's wife runs the catering side having feed up to 50 people for a Saturday evening meal a couple of years back when we had 30 starters for the Texaco comp. This is all in the middle of a cow paddock, with roof and tarp cover only. However, we do have good facilities as in proper flushing toilet with septic system and a hot shower run from a donkey hot-water system using kero and diesel mix. My Wife Karen run the catering for the first 11 years of the comp, its a massive job.

Below: Steve Archer's Lanzo Record Breaker on its way.... up ! Steve is from Mackay, Qld. Club.



The Chuck Glider comp is taken very seriously for those who get up early. Its general intent is to get the children involved. I have pics of the children which I haven't sent as one can't print them publically without parents' permission etc. Some times Mike the CD will nominate a particular type of model and send those interested the plans, or other years it's what ever you like, usually stick and rubber band launched though.



Chuckies stacked up awaiting the action.

supporters over the years closely followed by Townsville, Mackay and Innisfail. We have normally seen a field of around 25 competitors on the start line for the Texaco event but recently broke our record with a line-up of 30 starters, two years ago. The increase in numbers is from new competitors travelling from Brisbane, NSW and Victoria with positive feedback from these fellow modellers.

Since then we have developed our program to now run Texaco, Duration, Burford, Radian glider, catapult glider and this year we are considering adding 1/2A or Radio assist scramble.

This year will be our 20<sup>th</sup> year since our first event which coincides with the year 2020 and if covid-19 restrictions allow, we hope to run a postponed celebration event on the Queen's Birthday event in October.

Sarina Aero Modellers has certainly matured and gained respect for its annual OT championship and I recommend to you all to consider joining us at least once to experience fellowship, keen competition and good memories. If not this year then we hope to see you in 2021.

Keep flying high

Sarina Aero Modellers



All of the above are members of Sarina Aero Modellers except for fellow on right in the background. Mike, our CD, is in the middle, with two sons and grandsons. From left Nate Fiske, Craig Rankin and grandson Conner Rankin, Mike Rankin "CD", grandson Rylan Rankin and son Andrew Rankin who both live at Gold Coast. Fellow in back ground with overalls on Les Pelley.

We are very serious about safety but they try to run a stress free weekend for our guests.



Above: Dawn chuckie test flight, got to be a serious competitor.

Right: The early morning chuckie contestants ready to go.





Left: Les Morris from Innisfail Nth. QLD with his mate off-siding whose name escapes me, sorry.

We prefer to have our comp mid July so it's cooler up here.

This year with co-vid we are looking at October which can be quite humid already, so not as nice a time of the year.

Top Right: Take-off. Steve Archer is pretty new to Old Timer and hails from the Mackay Club, approximately 55klm from our club at Sarina. Steve only flew electrics but we have converted him to four stokes - ha! ha!



Middle Right: A pre-flight safety talk and welcome by CD Mike Rankin before Texaco competition.

Middle Left: Part of the Texaco line up "out on the line".

Bottom Left and Right: These speak for themselves. Lots of Bombers



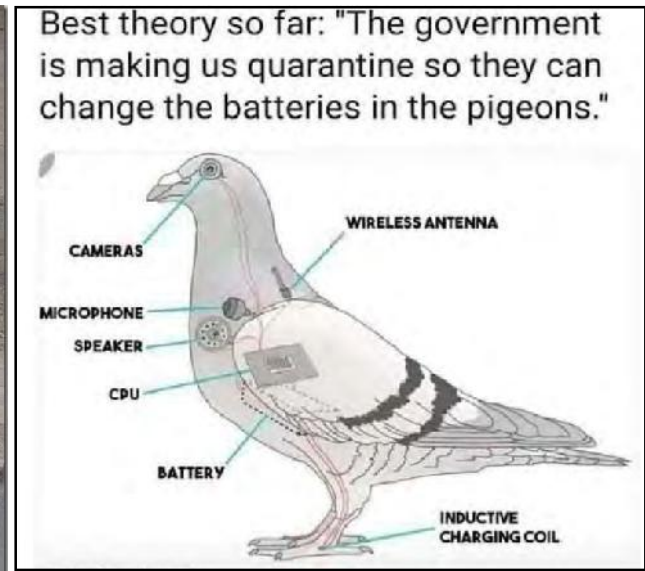

**The drop in petrol price during the lockdown is like a bald man winning a hairbrush**

Oldtimers



**NASA and Lockheed plan to start X-59 jet flight testing next year**

The Lockheed Martin X-59 QueSST (Quiet Supersonic Transport) developed for NASA's Low-Boom Flight Demonstrator program is soon to take off into the atmosphere.

The experimental supersonic aircraft has been built with an aim to find a solution to one of the most enduring challenges of supersonic flight - the sonic boom. The design features of X-59 QueSST reducing sonic booms are known now, however the main question is whether the aircraft is capable of retaining its unique shape, that reduces the boom, while in the air. According to Craig Nickol, manager of NASA's Low-Boom Flight Demonstrator project, there are a lot of variables that are difficult to model when the real aircraft gets into the real atmosphere.

What also needs to be clarified is how the jet's sound will move through the atmosphere and how people will view the softer sonic noise.

The flight testing is expected to begin in 2021, which should clear up the uncertainties and answer all the arising questions. The data received during the testing will be provided to the regulators, who will use the information to build an acceptable commercial supersonic noise standard in order to lift the ban set on commercial supersonic travel over land.

Should this mission be successful, it will likely lead to a renaissance in the industry. The new global market would be opened and the travel time for passengers would take half the time it currently takes, which is a major milestone.



## What Happened To The Twin Fuselage Stratolaunch with 6 Boeing 747 Engines?

By Nicholas Cummins May 6, 2020

Early last year, the fantastic Stratolaunch took to the skies and set new records with the biggest wingspan on an aircraft ever built at 385 feet (117 m). It was designed as a new delivery method for air-to-orbit rockets. What happened, and will it ever fly again?



*The record-breaking Stratolaunch aircraft completed its first successful flight in the Mojave Desert in April 2019.*

### What are the details?

The Stratolaunch aircraft (full name the Scaled Composites Model 351 Stratolaunch) is a colossal aircraft capable of carrying rockets between its twin-fuselages. Using the power of its six Boeing 747 Pratt & Whitney PW4056 engines, the aircraft platform can climb up to a cruising altitude of 35,000 ft (11,000 m) to launch a rocket into outer space. If we were to suggest that a rocket needed to reach 328,000 ft (100km) to enter orbit, then the aircraft is capable of carrying the 550,000 lb (250 t) rocket 10% of the way.

Much of the design is based on the Boeing 747-400, replicating much of the avionics, engineering, power plants, and more to reduce the \$400 million cost of the project. You may notice the two cockpits on the aircraft. The captain and co-pilot sit on the right cockpit, and the unpressurized left cockpit houses the data control systems.

The aircraft is not designed for range at all, and can only fly 2,500 nautical miles (4,600 km) when ferrying up to 250t of equipment, or up to 1,000 nautical miles when launching rockets.

### Has it ever flown?

The Stratolaunch completed a test flight back in April 2019.

It flew for two and a half hours at an altitude of 17,000 feet over the desert, reaching a maximum speed of 189 miles-per-hour. While in-flight, several tests were conducted to evaluate the aircraft's flight control systems and to test its handling. It successfully navigated through a long list of manoeuvres such as roll doublets, yawing manoeuvres, steady heading side slips, and simulated landing approaches.

As we reported back in April last year, we suggested that "this successful flight will no doubt be the first of many for the progressive aircraft company." Alas with the passing of the CEO (Microsoft's Paul Allen), funding dried up, and the team found themselves putting the aircraft up for sale.

### When will it fly again?

In June 2019, the company shopped itself around for US\$400 million. This sale included the sole aircraft, the company facilities, equipment, designs, and other intellectual property. As you can imagine, either this concept would be instantly snapped up for its very unique technologies, or it would never find a buyer.



*The record-breaking Stratolaunch aircraft completed its first successful flight in the Mojave Desert in April 2019.*

Fortunately, the latter seems to have occurred, and by October 2019, the firm reported that they had found a new group of investors.

The company has changed direction and now offers the Stratolaunch aircraft for high-speed test services. Companies that are developing rockets or hypersonic aircraft plan to use the platform to get their plane up to altitude before performing rocket tests.



Noticing that many space clients want a full solution to orbit (not just a halfway option), the company is also developing its own take on rocket engines to launch cargo into orbit by 2023.

We have not seen the last of the Stratolaunch and will look forward to its shadow crossing the desert in the future.

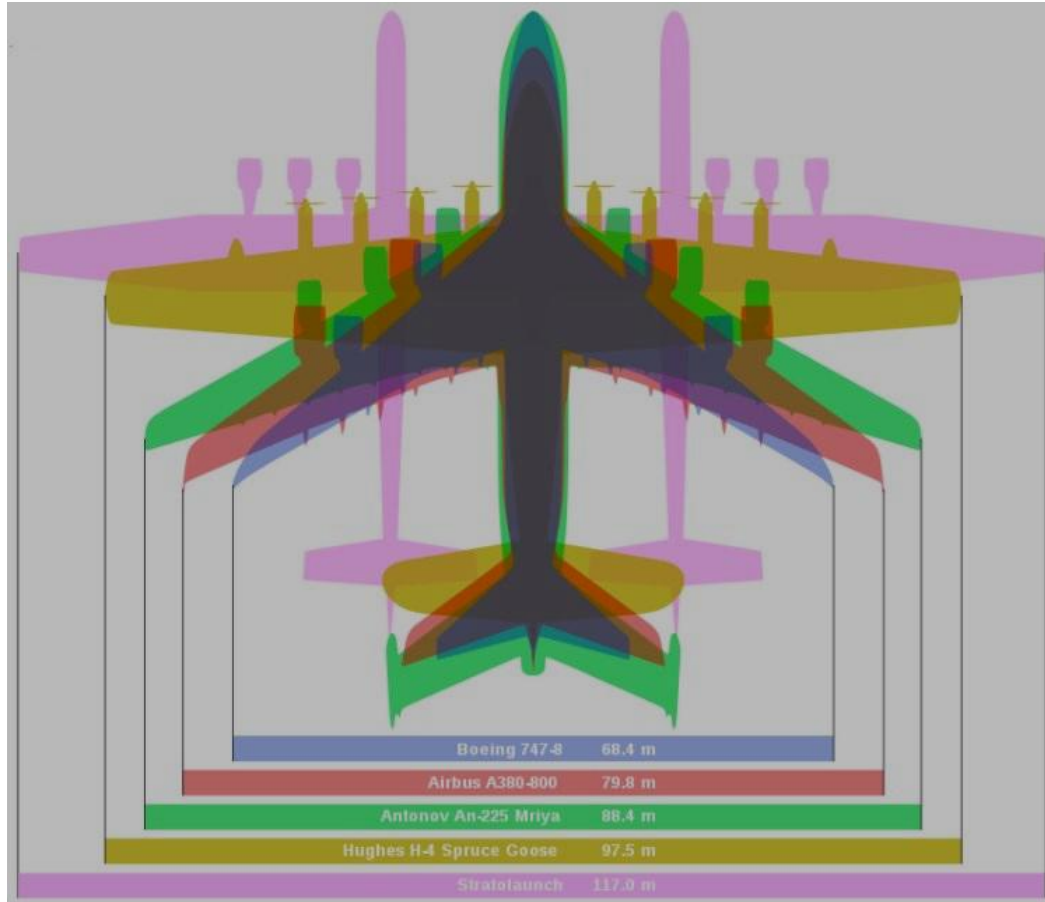

The Stratolaunch wingspan compared to other large aircraft.



"Halfax" introduces ~

"The Albatross"

A HIGH EFFICIENCY SAILPLANE OF 66 IN. WING SPAN TO F.A.I. LOADING, COMBINING GOOD LOOKS WITH EXCELLENT PERFORMANCE. EQUIPPED WITH ALL THE LATEST DEVELOPMENTS IN TOW-LAUNCH GLIDING TECHNIQUE—ADJUSTABLE NOSE WEIGHT, RUDDER & AILERON CONTROL, TOW-LINE STABILITY DESIGN AND CON-

PRICE 25/-  
POST 1/-

TAILPLANE TIP FINES FOR AMONGST MANY OTHER STRUCTURAL FEATURES



Model Aero Supplies

MANUFACTURERS & EXPORTERS • GREEN MOUNT WORKS • HALIFAX • YORKSHIRE  
TEL. HALIFAX 2729

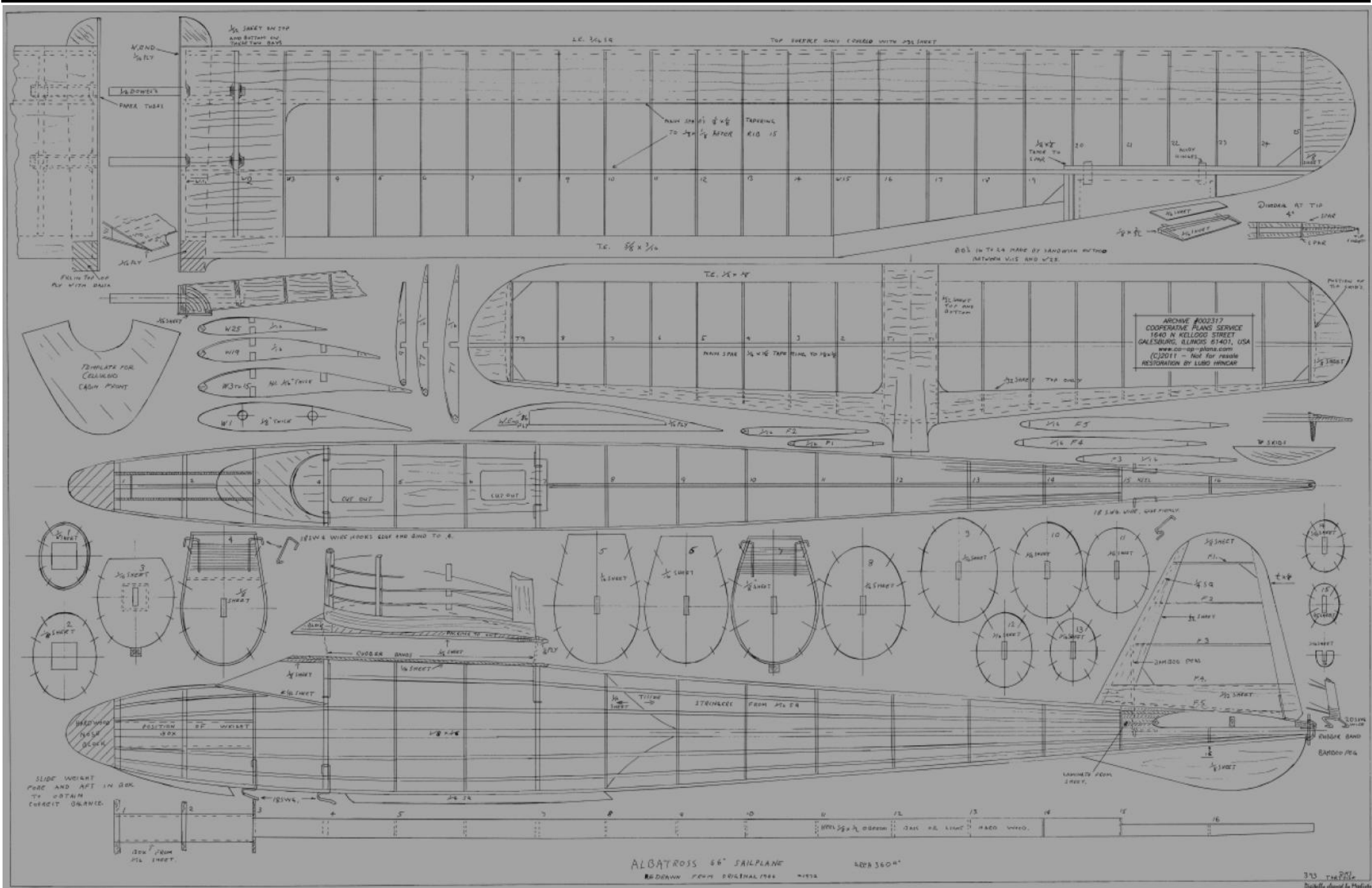

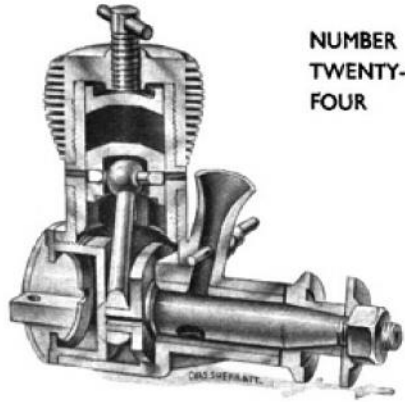

NUMBER TWENTY-FOUR

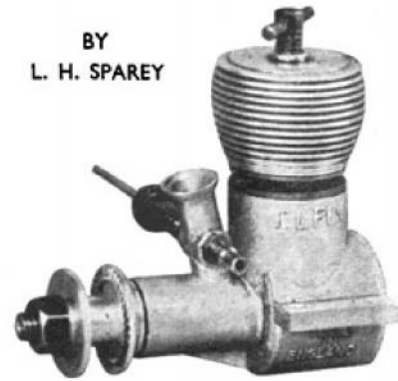

BY L. H. SPAREY

# The ELFIN 1.49

ACTUAL SIZE

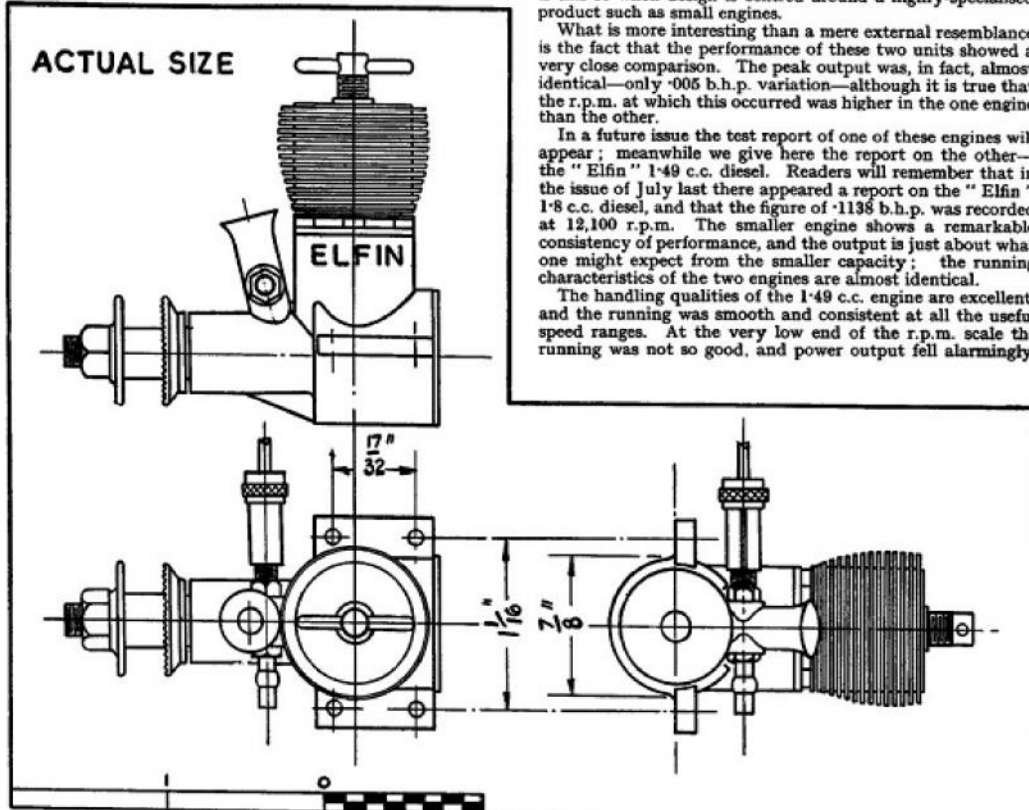

**A**N opportunity has just arisen to test two small diesels of identical capacity but of different manufacture, and the comparative results are most interesting. Both these engines are of the modern, "hot-stuff" type, using uniflow porting, short stroke, and rotary inlet valve via the crankshaft. They are, in fact, so extremely similar in design that a change over of the cylinder heads would make difficult to distinguish which was which at a casual glance.

Such a similarity in appearance is almost bound to occur when designers are aiming at the same thing, because logical thinking along similar lines is bound to lead to similar conclusions. Anyone who has tried to take out a patent will have been amazed at the number of similar ideas which have been invented, in almost identical form, by folk living poles apart. When two things, such as small engines, bear a marked resemblance to one another, it is extremely unsafe to say that either of them has been "copied" from the other. Especially is this so when design is centred around a highly-specialised product such as small engines.

What is more interesting than a mere external resemblance is the fact that the performance of these two units showed a very close comparison. The peak output was, in fact, almost identical—only .005 b.h.p. variation—although it is true that the r.p.m. at which this occurred was higher in the one engine than the other.

In a future issue the test report of one of these engines will appear; meanwhile we give here the report on the other—the "Elfin" 1.49 c.c. diesel. Readers will remember that in the issue of July last there appeared a report on the "Elfin" 1.8 c.c. diesel, and that the figure of .1135 b.h.p. was recorded at 12,100 r.p.m. The smaller engine shows a remarkable consistency of performance, and the output is just about what one might expect from the smaller capacity; the running characteristics of the two engines are almost identical.

The handling qualities of the 1.49 c.c. engine are excellent, and the running was smooth and consistent at all the useful speed ranges. At the very low end of the r.p.m. scale the running was not so good, and power output fell alarmingly.

This is undoubtedly due to the porting arrangements, which seem to be designed for the quick cut-off necessary for high-speed efficiency. The engine was also notable for the extremely high speed at which the maximum power output was developed—almost 14,000 r.p.m. This is, I believe, the highest maximum speed/power figure yet recorded for miniature diesel engines.

In spite of the high speed at which this engine was tested, no mechanical trouble was experienced, and the unscrewing of parts which was encountered while testing the larger Elfin engine seems to have been cured.

### TEST

**Engine:** "Elfin" 1.49 c.c. Diesel.

**Fuel:** Mercury No. 3 and Mercury Special Ether: 1-1.

**Starting:** The engine was experimentally hand-started from time to time, with engine both hot and cold, and response was immediate in all cases. For convenience, pulley and cord starting was employed for the main tests. The starting position of the needle valve, as marked on the test card, was fairly accurate, and should enable the novice to obtain a quick start.

**Running:** Extremely consistent at all speeds above about 5,000 r.p.m., but was inclined to be "lumpy" at speeds below this figure. Considering that this unit is definitely in the "hot" class, it was remarkably free from temperament.

**B.H.P.:** A maximum output of exactly .10 b.h.p. was recorded at the high figure of 13,700 r.p.m. The peak of the curve is not exceptionally flat, as between 12,000 and 14,000 r.p.m. the rather large drop of .005 b.h.p. is encountered. At 10,000 r.p.m. the output is reduced to .085 b.h.p., and at the lowest tested speed of 8,000 r.p.m. the output was only .053 b.h.p. At the other end of the scale it will be seen that power drops steeply once the 14,000 r.p.m. mark has been reached. It seems desirable that this engine be run between 13 and 14,000 r.p.m. for maximum efficiency.

**Checked Weight:** 2.7 ozs. less tank.

**Power / Weight Ratio:** .549 b.h.p./lb.

**Remarks:** The engine was run-in for one hour at 5,000 r.p.m., and no mechanical trouble was experienced throughout the tests. An interesting feature of this engine lies in the use of cast iron for the piston and main bearings—a material which I strongly advocated for these purposes in this journal as long ago as 1935. When properly fitted and run-in such bearings can be practically everlasting.

### GENERAL

#### CONSTRUCTIONAL DATA

**Name:** Elfin.  
**Manufacturers:** Aerol Engineering, Henry Street, Edge Lane, Liverpool 13.  
**Retail Price:** £2. 19s. 6d  
**Delivery:** Immediate.

- Spares:** Immediate.
- Type:** Compression Ignition.
- Specified Fuel:** Castor oil 1/3, paraffin 1/3, ether 1/3.
- Capacity:** 1.49 c.c., .091 cu. in.
- Weight (bare):** 2½ ozs.
- Compression Ratio:** 14:1 to 10:1.
- Mounting:** Beam, upright or inverted.
- Recommended Airscrews:** Free Flight, 8 in. x 4 in. Control Line, 7 in. x 6 in.
- Recommended Flywheel:** 3 ozs.
- Bore:** .503 in. **Stroke:** .460 in.
- Cylinder:** One piece, attached by 40 T.P.I. thread.
- Cylinder Head:** 40 T.P.I. thread.
- Crankcase:** Pressure die-cast.
- Piston:** Angular deflector, no rings.
- Connecting Rod:** Duralumin.
- Crankpin Bearing:** Plain. **Crankshaft:** Nickel chrome.
- Main Bearing:** Cast iron. **Little End Bearing:** Plain.
- Crankshaft Valve:** Rotary valve.
- Cylinder Liner:** Nickel chrome steel.

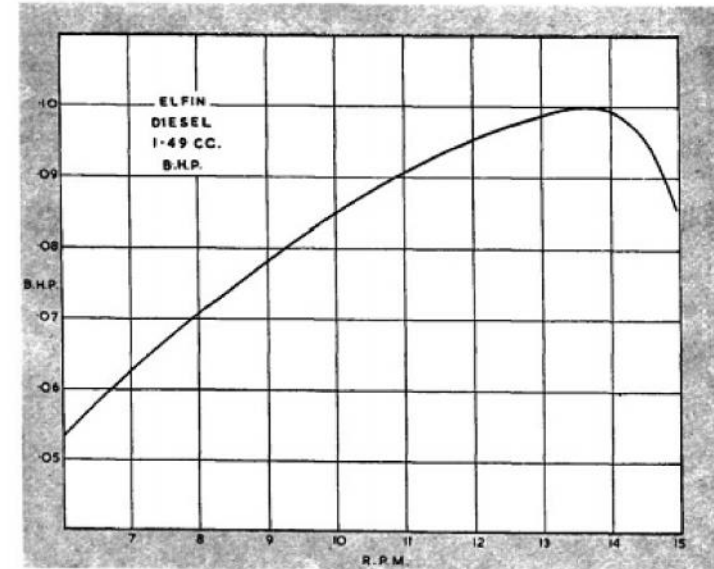



# ALICE SPRINGS Masters Games

10-17 October 2020

*The Friendly Games*



<https://www.alicespringsmastersgames.com.au/>

## History

In the early 1980's the Australian Sports Commission first suggested an idea of a masters games and the philosophy of masters sport. The development of masters sport included an underlying belief that each participant is a champion in his or her own right, as long as the physical and mental attributes for each stage of life have been maintained at their peak.

The Northern Territory Government immediately recognized the potential opportunities for economic and social development. In 1986 the first ever Masters Games were held in Alice Springs.

The 1986 Alice Springs Masters Games were the first of their kind in the world. The Masters in Territory of Australia.

The Games are a celebration of sport events that have earned the reputation of good spirit and good sportsmanship by the games will be held around Australia and have experienced the Alice Springs.

The 'Friendly Games' Alice Springs Master Games have been held for years. In 2004 the Games rejoiced as the Alice Springs. What is even more notable is that officials and volunteers have made a remarkable achievement for all.

Participation in sport is a life-long activity. Masters sports contain fun, camaraderie and good-spirited competition. That is why the Alice Springs Masters Games adventure continues in 2020.



**Cancelled**  
It is with great disappointment the Alice Springs Masters Games cannot go ahead this year. Multi-sport events take years of careful planning, and uncertainties created by the COVID-19 pandemic mean it is impossible to plan satisfactorily for a quality event in 2020. Registered participants will be contacted to arrange a full refund.  
We know there will be many disappointed people out there, but rest assured we are already planning for the 2022 Alice Springs Masters Games, and we look forward to delivering a world-class event for you to enjoy.

Registrations:  
<https://asmg.fusesport.com/registration/1239>

- Runway 2: Glider F5J  
Undoolya Rd
- Thursday 15**  
9:00am - Runway 1: IMAC Competition, Runway 2: Old Timers Competition, Peddler Field Undoolya Rd
- Friday 16**  
TBA - Runway 1: IMAC Competition, Runway 2: Glider F5J Competition, Peddler Field Undoolya Rd
- TBA - Runway 1: Contingency, Runway 2: Old Timers Competition, Peddler Field Undoolya Rd
- Tuesday 13**  
TBA - Runway 1: IMAC Practise, Runway 2: Old Timers Competition, Peddler Field Undoolya Rd
- Wednesday 14**  
TBA - Runway 1: IMAC Competition, Runway 2: Glider F5J Competition, Peddler Field Undoolya Rd



# THE BACK PAGE



One of Australia's perfect slope/soaring sites?  
Mount Borah, Manilla, NSW.  
Photo - Karen Paton.